

Compu-M



Instruction Manual

PL-516

December 1996

Thank you for purchasing Milltronics' products. We endeavour to design equipment that is simple to use and reliable in its operation, with the aim of satisfying our customers' needs.

Milltronics has been designing and manufacturing process equipment since 1954. Our fields of expertise include ultrasonic level measurement, in-line weighing of dry bulk solids and motion sensing.

Milltronics is established world wide through associate offices and representatives. Our network is continually being refined to provide our customers with first rate sales information, engineering assistance and after sales support.

For more details on our products and service, please contact us and we will provide you with a listing of the offices or representatives nearest you.



Canada : 1954 Technology Dr., P.O. Box 4225, Peterborough, Ontario, Canada K9J 7B1
Tel.: 705-745-2431 Fax: 705-741-0466

U.S.A. : 709 Stadium Drive, Arlington, Texas U.S.A. 76011
Tel.: 817-277-3543 Fax: 817-277-3894

England : Oak House, Bromyard Road, Worcester, England WR2 5XZ
Tel.: 01905-748404 Fax: 01905-748430

France : Parc de la Sainte Victoire, Bât. 5, 13590 Meyreuil, France
Tel.: +33 4 42 65 69 00 Fax: +33 4 42 58 63 95

Belgium : August van de Wielelei 97, 2100 Deurne, Antwerp, Belgium
Tel.: 03/326 45 54 Fax: 03/326 05 25

Mexico : Amores No. 1155, Col. Del Valle, 03100 Mexico D.F., Mexico
Tel.: 575-31-44 / 575-83-13 / 575-27-78 Fax: 575-26-86

Internet : <http://www.milltronics.com>



TABLE OF CONTENTS

| Section | Page |
|-------------------------|-------------|
| GENERAL INFORMATION | |
| The Compu-M | 5 |
| About the Compu-M | 5 |
| SPECIFICATIONS | |
| Compu-M | 7 |
| Current Output Isolator | 8 |
| Cabling | 9 |
| Options | 9 |
| INSTALLATION | |
| Compu-M | 11 |
| Outline and Mounting | 12 |
| Compu-M Layout | 13 |
| Interconnection | 14 |
| System Diagram | 14 |
| Compu-M / Belt Scale | 15 |
| Compu-M / MMI-2 | 16 |
| Compu-M / Speed Sensor | 17 |
| Compu-M / Flowmeter | 18 |
| Ancillary Connections | 19 |
| Power Connections | 22 |
| PROGRAMMING | |
| Operating Modes | 23 |
| Keypad | 23 |
| Parameter Entry | 24 |
| Display Messages | 25 |

APPLICATIONS

Belt Scales

| | |
|-----------------------------|----|
| Operation | 27 |
| Initial Start Up | 28 |
| Programming Chart - Example | 35 |
| Recalibration | 36 |

Solids Flowmeters

| | |
|-----------------------------|----|
| Operation | 41 |
| Test Rate | 42 |
| Initial Start Up | 42 |
| Programming Chart - Example | 48 |
| Recalibration | 49 |

| | |
|------------|----|
| PARAMETERS | 53 |
|------------|----|

| | |
|-------------------|----|
| PROGRAMMING CHART | 69 |
|-------------------|----|

GENERAL INFORMATION

ABOUT THIS MANUAL

It is essential that this instruction manual, PL-453, be referred to during the installation and start up of the Compu-M.

Applications, provides operation, and programming/calibration information specific to Compu-M applications. The programming/calibration of the Compu-M may be further optimized by referring to *Parameters*.

To assist the operator in programming the Compu-M, a *Programming Chart* is provided. Transfer the required data from the Design Data Sheet or the values established from *Parameters* onto the Programming Chart. The Programming Chart parameter orientation is designed to permit convenient sequential parameter programming. The programming chart may be folded out so the chart and *Parameters* may be reviewed simultaneously.

ABOUT THE COMPU-M

The Compu-M is to be used only in the manner outlined in this instruction manual.

The Compu-M is a microprocessor based integrator designed specifically for bulk dry solids in-line weighing applications.

If the current material transport system is by conveyor belt, the Compu-M is used in conjunction with a belt scale. The Compu-M provides a local display of: load, speed, flowrate and total flow.

If the application material is free flowing, the Compu-M is combined with a dry solids flowmeter. The Compu-M provides flowrate and total flow displays.

The Compu-M also provides an analog mA output signal proportional to flowrate, a contact for remote totalizer operation and a relay contact for rate alarm.

Programming is accomplished via the front cover membrane keypad. The Compu-M prompts the operator to enter the information required to complete basic programming. Additional programming features may be utilized to tailor the Compu-M operation to a specific application.

The level of operator access may be defined to ensure programming is not inadvertently altered during normal operation.

Calibration is automatic and relatively simple to achieve. In the calibrate mode, operating conditions are simulated to perform a zero and span calibration. A material test may then be performed to verify system accuracy. If required, the Compu-M may be programmed to correct any accuracy deviation.

During normal operation the user may select any of the available local displays and select the display light if desired. Access to the totalizer reset feature and other functions may be permitted depending on the level of operator access chosen when the system was programmed.



SPECIFICATIONS

COMPU-M

- Power :
- » standard : » 100/115/200/230 V ac± 10%, 50/60 Hz, 15 VA
 - » optional : » 12± 2 V dc, 15 W
 - » 24± 4 V dc, 15 W
- Environmental :
- » location : » indoor
 - » altitude : » 2000 m max
 - » ambient temperature : » – 20 to 50 °C (– 5 to 122 °F)
 - » relative humidity : » 80 % for temperatures up to 50 °C
 - » installation category : » II
 - » pollution degree : » 2
- Inputs :
- » load cell : » 0 - 45 mV dc per load cell, 2 cells maximum
 - » LVDT : » 0 - 0.75 V rms, 2.9 kHz
 - » speed sensor : » 5 - 15 V dc pulses, 2 Hz to 10 kHz (for belt scales only)
- Outputs :
- » analog : » 0.1% resolution
 - » 0 - 20 or 4 - 20 mA, non-isolated
 - » 750 Ω maximum load
 - » speed sensor excitation : » 12 V dc, 50 mA maximum
 - » totalizer, remote : » contact closure 32-288 ms duration
 - » 1 form "C" relay contact rated 2 A at 250 V ac, 50 VA maximum resistive
 - » 15 closures per second maximum
 - » alarm relay : » 1 S.P.D.T. contact rated at 5 A at 250 V ac non-inductive
 - » load cell excitation : » 10 V dc nominal, 100 mA maximum
 - » LVDT excitation : » 2.5 V ac rms, 2.9 kHz
- Displays :
- » liquid crystal : » 8 digits, 13 mm (0.5") high with backlight
 - » LED : » 4 display mode indicators
- Accuracy :
- » ± 0.1% of span

- Resolution : » $\pm 0.02\%$ of span
Memory : » EEPROM (non-volatile) no back-up battery required
- Enclosure : » standard : » 209 mm W x 285 mm H x 92 mm D
(8.2" W x 11.2" H x 3.6" D)
polycarbonate
- Keypad : » 20 key sealed membrane with tactile feedback
- Weight : » standard : » 2.5 kg (5 lb.)
- Approvals : » CE *, FM, CSA NRTL/C
* EMC performance available upon request

CURRENT OUTPUT ISOLATOR (optional)

- Model : » LIs-1 loop isolator
- Input : » 4-20 mA dc (from Compu-M)
- Output : » 4-20 mA dc into 600 ohms maximum
- Common Mode Rejection : » 100 dB at 50 Hz
- Weight : » 0.27 kg (0.6 lb.)

CABLING

- Load cell :
- » single, non-sensing : » Belden 8404, 4 wire shielded, 20 AWG or equivalent
» maximum run 150 m (500 ft.)
 - » single, sensing : » Belden 9260, 6 wire shielded, 20 AWG or equivalent
» maximum run 305 m (1000 ft.)
 - » dual, non-sensing : » Belden 9260, 6 wire shielded, 20 AWG or equivalent
» maximum run 150 m (500 ft.)
 - » dual, sensing : » Belden 8418, 8 wire shielded, 20 AWG or equivalent
» maximum run 305 m (1000 ft.)
- LVDT :
- » Belden 8404, 4 wire shielded, 20 AWG or equivalent
» maximum run 150 m (500 ft.)
- Speed sensor :
- » Belden 8770, 3 wire shielded, 18 AWG or equivalent
» maximum run 305 m (1000 ft.)

OPTIONS

- Incline compensator : » refer to product instruction manual, (for variable incline conveyors)
- Barrier strips : » required for intrinsic safety



INSTALLATION

**Installation shall only be performed by qualified personnel
and in accordance with local governing regulations.**

COMPU-M

The Compu-M should be mounted in an area that is within the units ambient temperature range, and is suitable for the specified enclosure. The front cover should be accessible for programming and viewing.

It is advisable to keep the Compu-M away from high voltage or current runs, contactors, and SCR control drives.

**This product is susceptible to electrostatic shock.
Follow proper grounding procedures.**

**Do not mount the COMPU-M in direct sunlight
without the use of a sunshield.**

OUTLINE AND MOUNTING

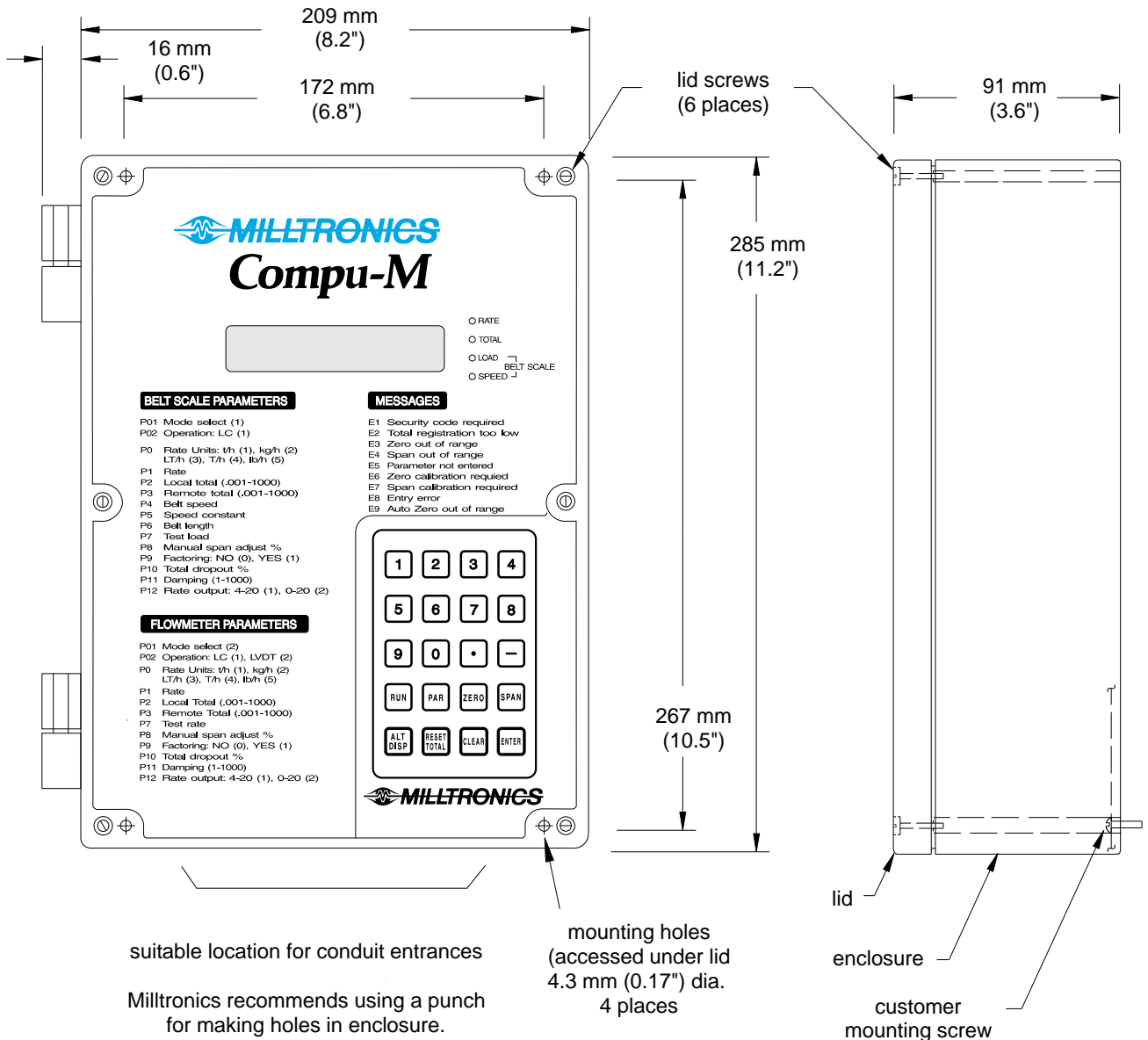

**Non metallic enclosure does not provide grounding between connections.
Use grounding type bushings and jumpers.**

COMPU-M LAYOUT

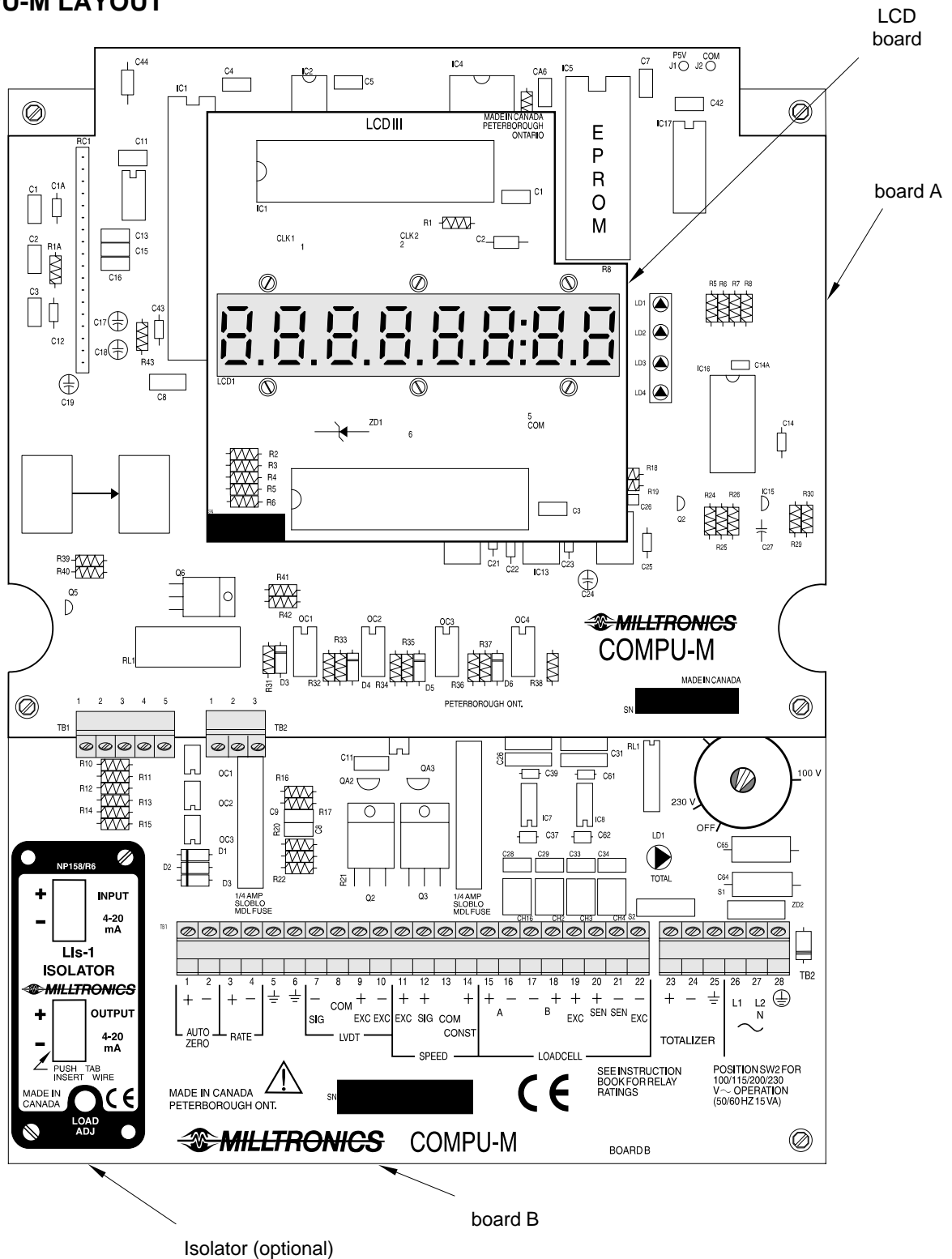

All field wiring must have insulation suitable for at least 250 V.



dc terminals shall be supplied from an SELV source in accordance with IEC-1010-1 Annex H.

INTERCONNECTION

Load cell or LVDT, speed sensor, analog mA output, auto zero and low voltage contact wiring may be run in a common conduit. However, these may not be run in the same conduit as high voltage contact or power wiring.

SYSTEM DIAGRAM

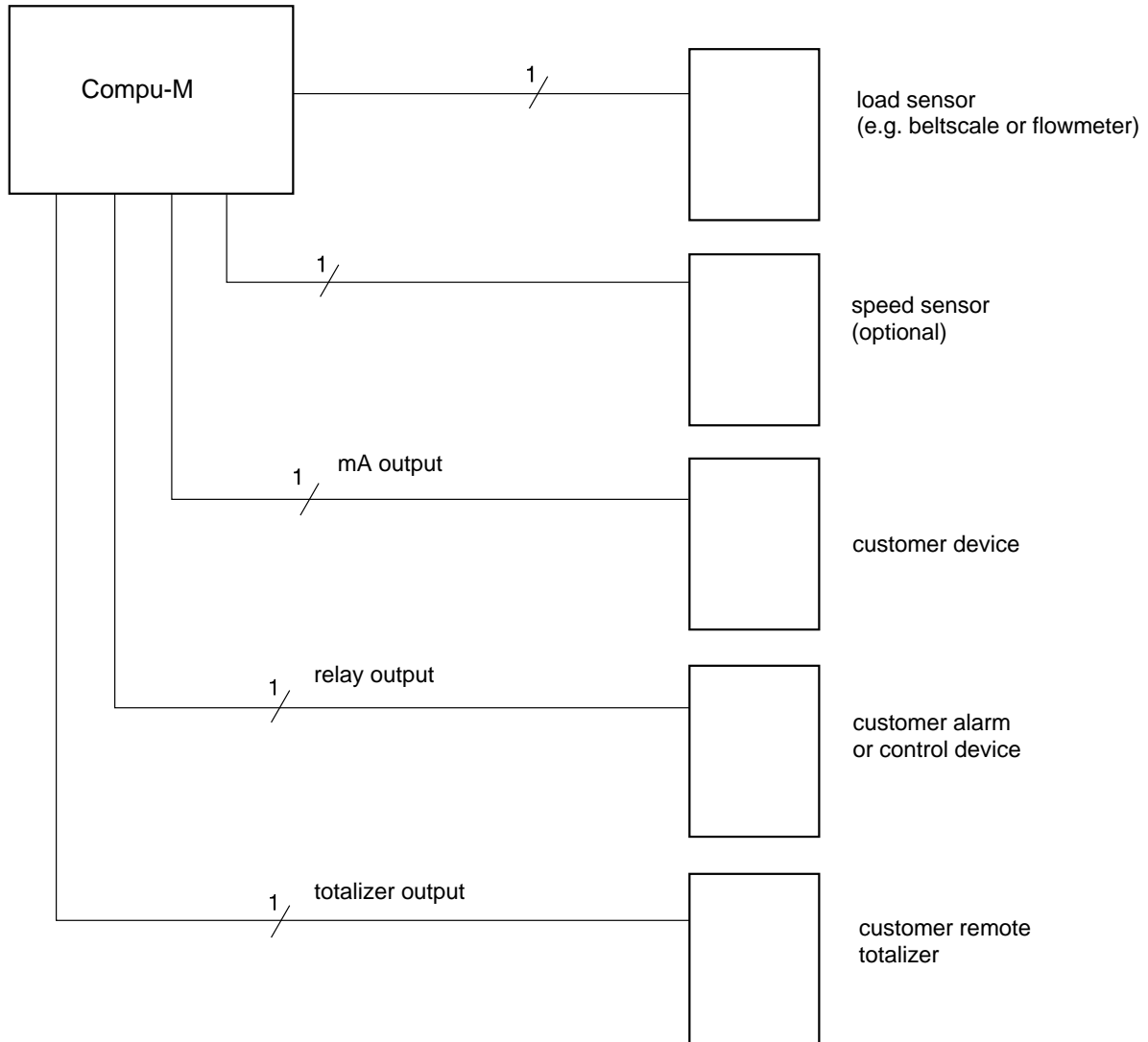

COMPU-M / BELT SCALE INTERCONNECTION

LVDT

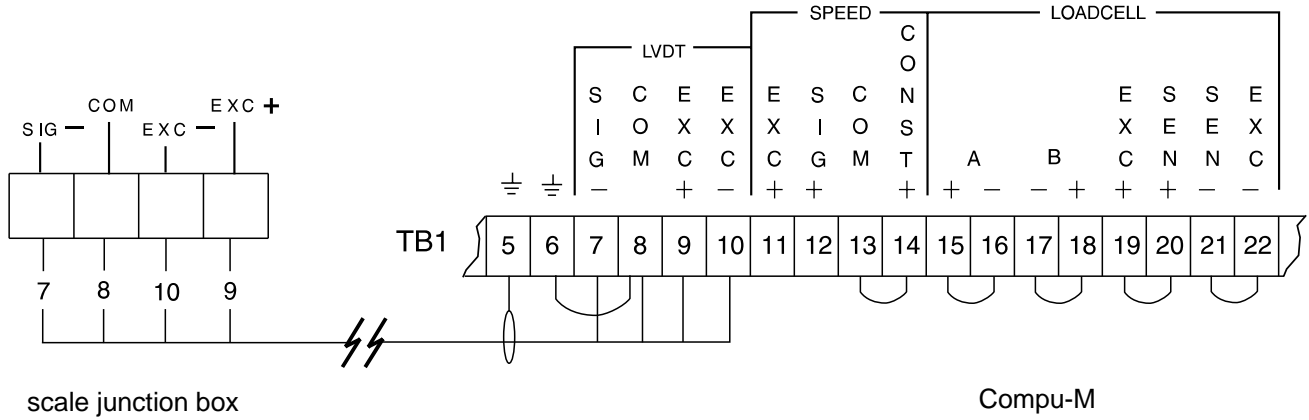

SINGLE LOAD CELL *

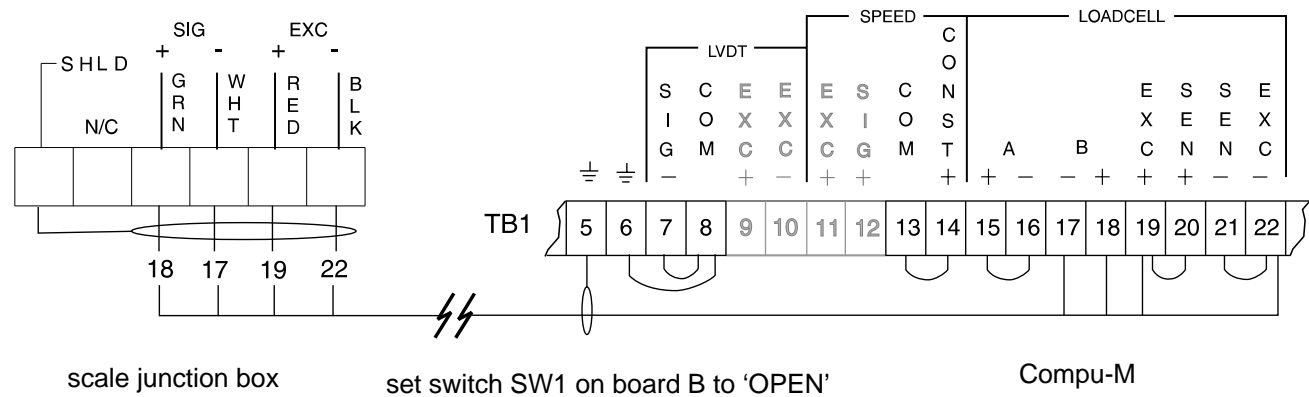

DUAL LOAD CELLS *

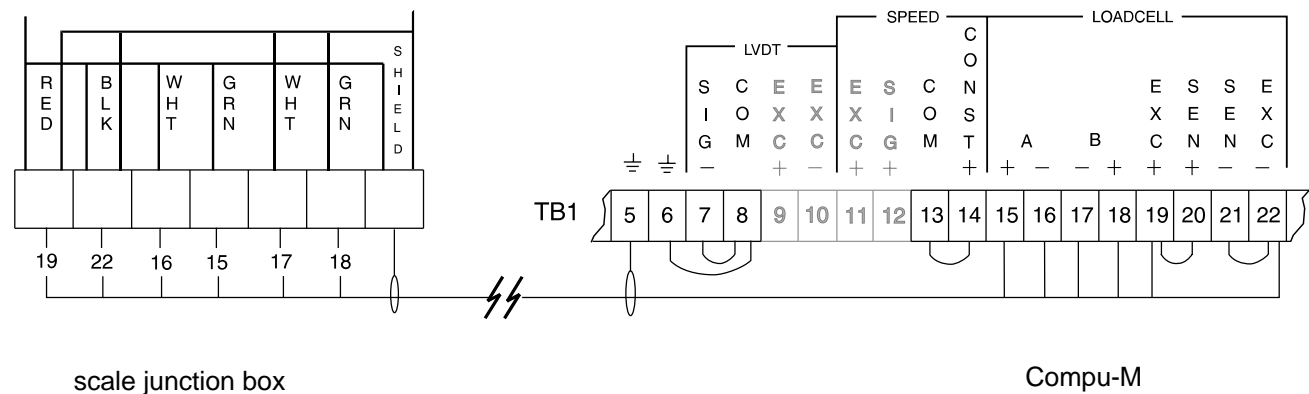

COMPU-M / MMI-2 (tandem dual load cells)*

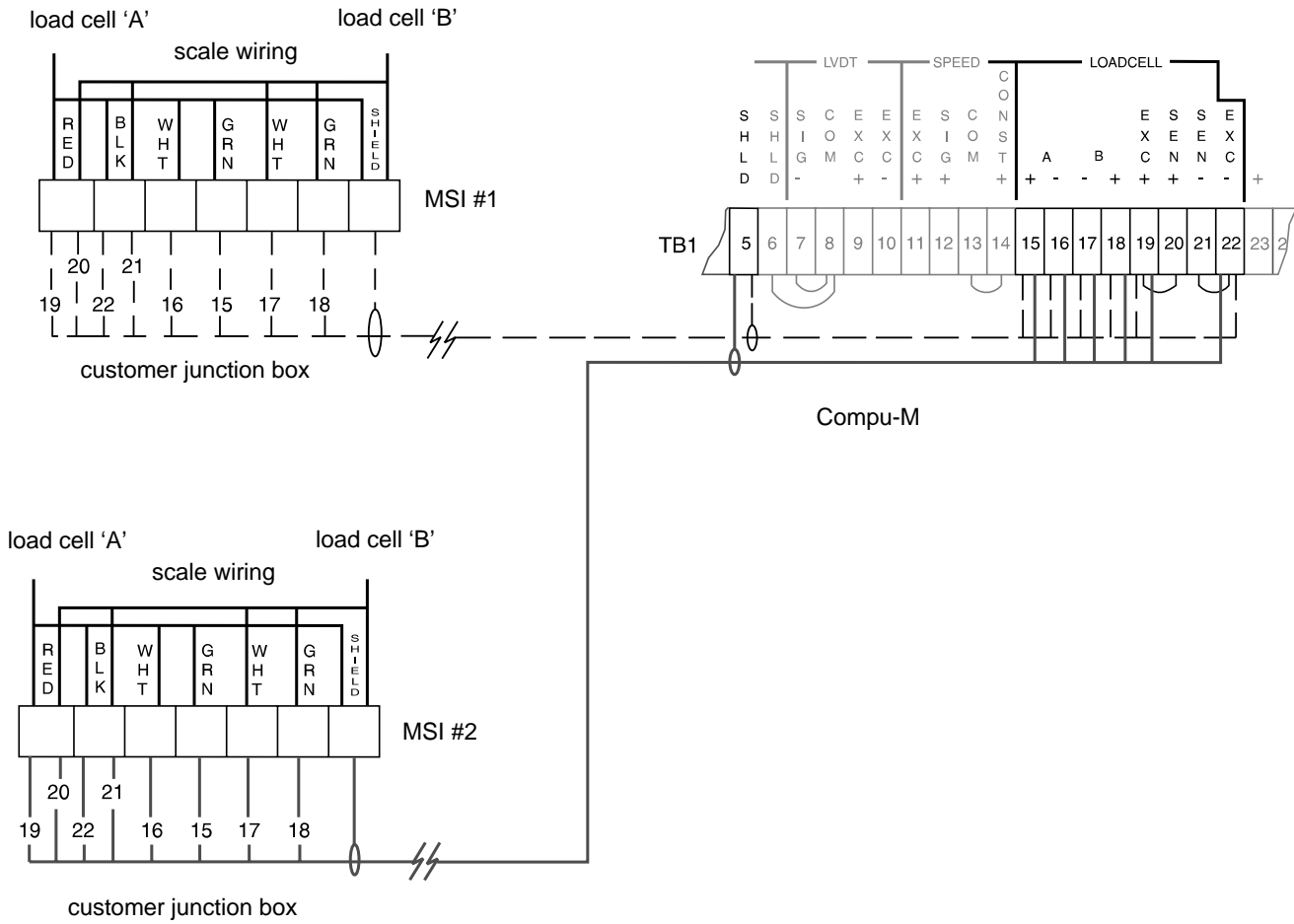

- * 1. Where a belt scale must be installed in a hazardous area, consult Milltronics or your distributor for wiring instructions.
- 2. Where the integrator to load cell belt scale separation exceeds 150 m (500 ft.) :
 - » A) remove jumpers from Compu-M (board B) TB1 - 19 / 20 and TB1 - 21 / 22
 - » B) run an additional shielded conductor from each of :
 - » Compu-M (board B) TB1 - 20 to junction box terminal '+ EXC' (red)
 - » Compu-M (board B) TB1 - 21 to junction box terminal '- EXC' (black)

COMPU - M / SPEED SENSOR ▲ INTERCONNECTION

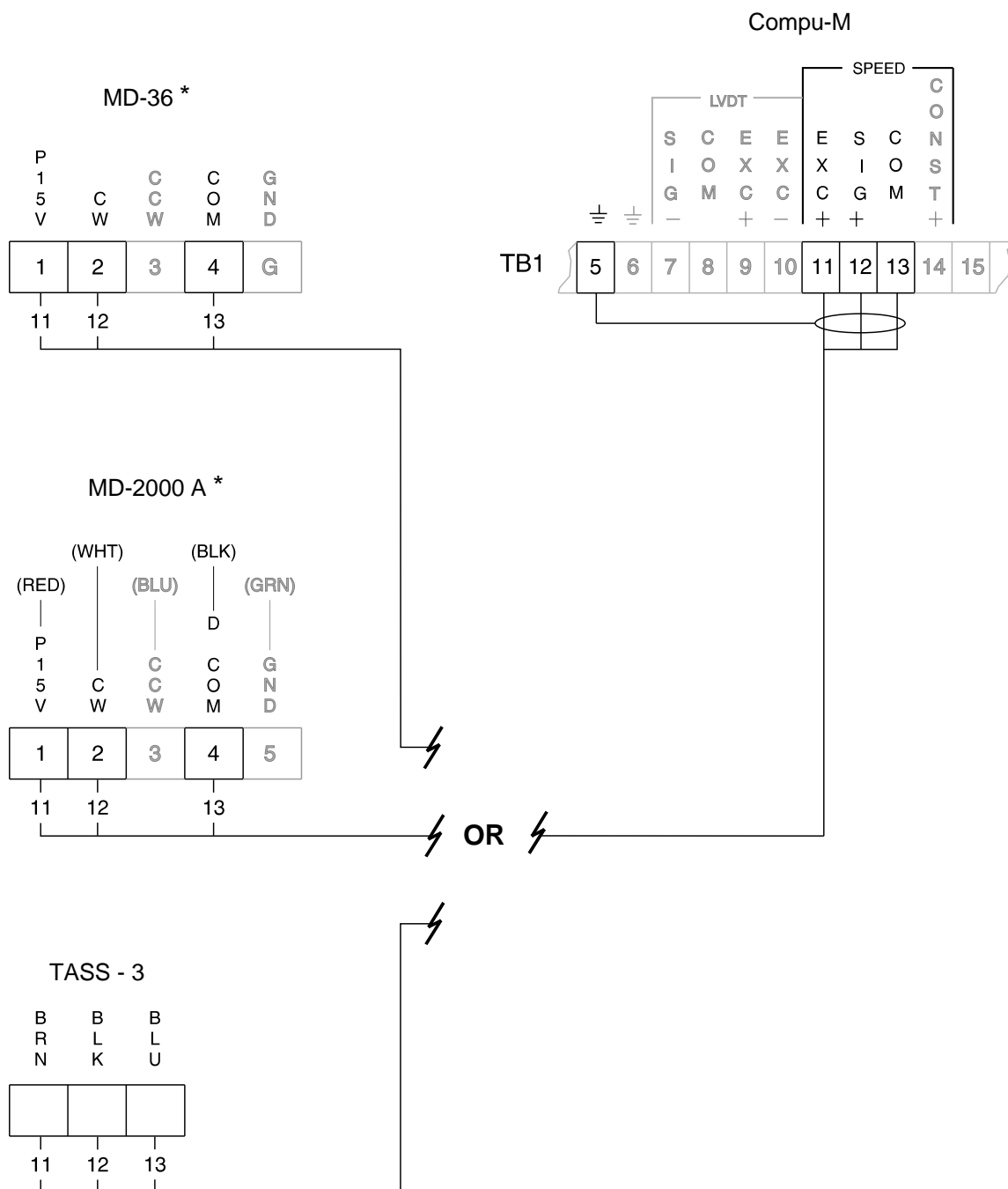

* Connect Compu-M (board B) TB1 - 12 to speed sensor terminal strip:

- » position '2' for clockwise speed sensor shaft rotation
- » position '3' for counter-clockwise speed sensor shaft rotation.

Speed sensor shaft rotation is viewed from the front cover side of the speed sensor enclosure.

▲ If a speed sensor is not used, a jumper must be connected across Compu-M (board B) TB1 - 13 / 14

COMPU-M / FLOWMETER INTERCONNECTION

LVDT

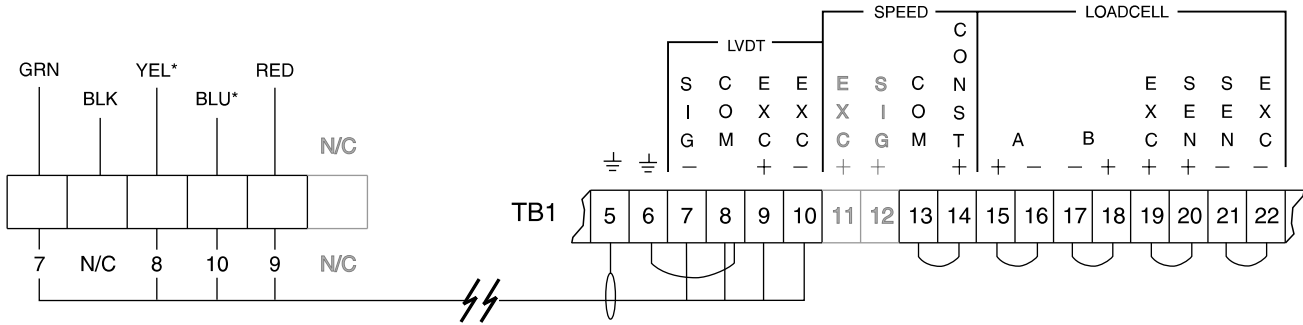

* For connection to an encapsulated LVDT (provided for hazardous environments) YEL = white and BLU = orange.

SINGLE LOAD CELL

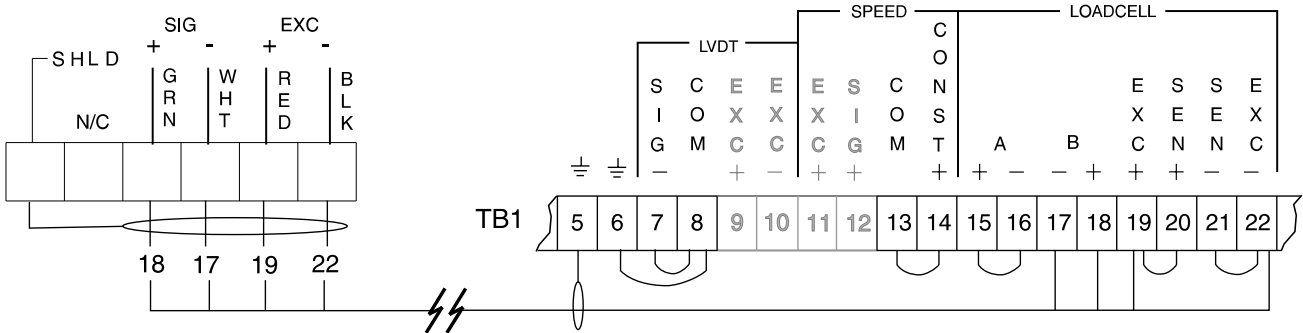

set switch SW1 on board B to 'Open'

DUAL LOAD CELLS

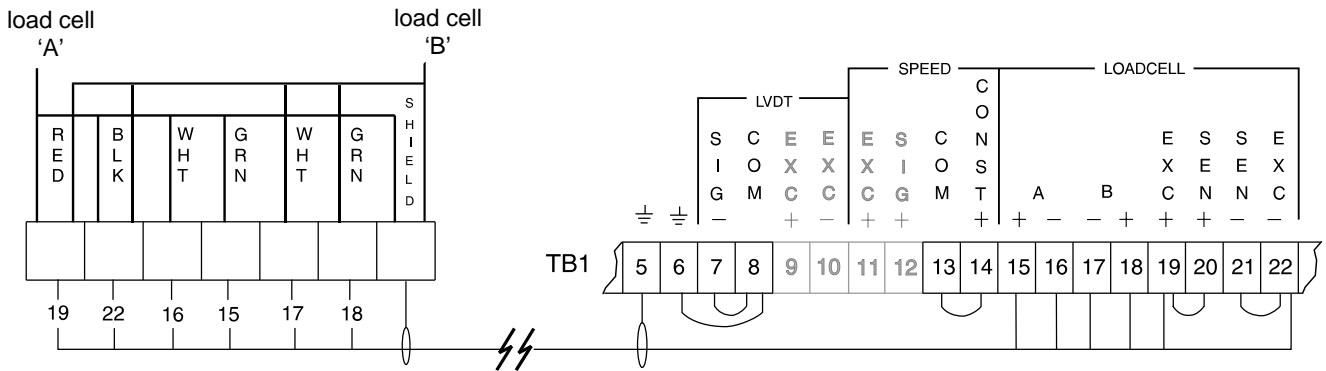

1. Where a belt scale must be installed in a hazardous area, consult Milltronics or your distributor for wiring instructions.
2. Where the integrator to load cell belt scale separation exceeds 150 m (500 ft.) :
 - » A) remove jumpers from Compu-M (board B) TB1 - 19 / 20 and TB1 - 21 / 22
 - » B) run an additional shielded conductor from each of :
 - » Compu-M (board B) TB1 - 20 to junction box terminal '+ EXC'
 - » Compu-M (board B) TB1 - 21 to junction box terminal '- EXC'

ANCILLARY CONNECTIONS

AUTO ZERO

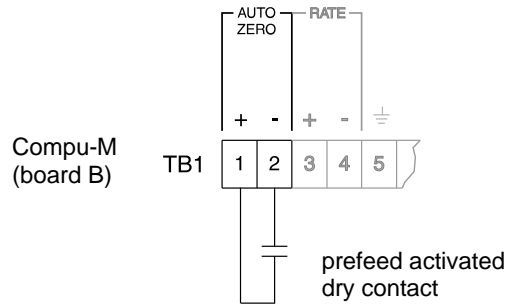

ANALOG OUTPUT

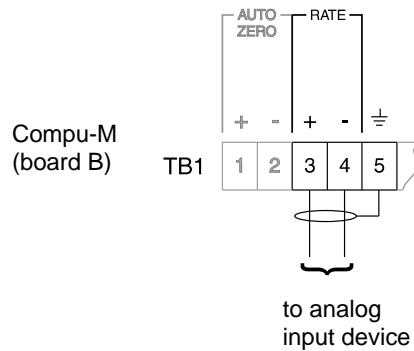

ANALOG OUTPUT ISOLATOR

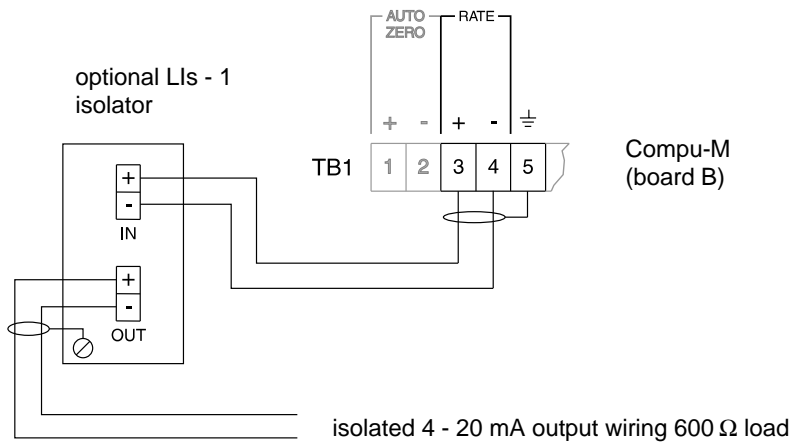

1. Auto Zero dry contact may be provided by a material prefeed control device, such that the contact is closed when the material feed is stopped.
2. Analog output must not be grounded, 750 Ω maximum load.
3. Compu-M to LIs - 1 isolator wiring by Milltronics if isolator is factory installed.

ALARM RELAY

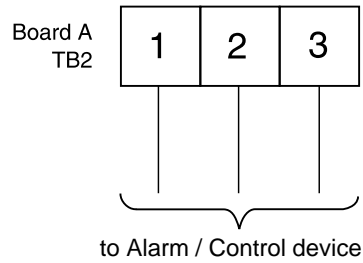

| | | |
|-----------------------------------|---------------------|--------------------|
| Relay not selected (P - 20 = 0) | TB2 - 1,2 = open, | TB2 - 2,3 = closed |
| Relay selected (Normal operation) | TB2 - 1,2 = closed, | TB2 - 2,3 = open |
| Relay selected (Alarm Condition) | TB2 - 1,2 = open, | TB2 - 2,3 = closed |

Relay is certified for use in equipment where the short circuit capacity of the circuits in which they are connected is limited by fuses having ratings not exceeding the rating of the relays.

REMOTE SWITCHES

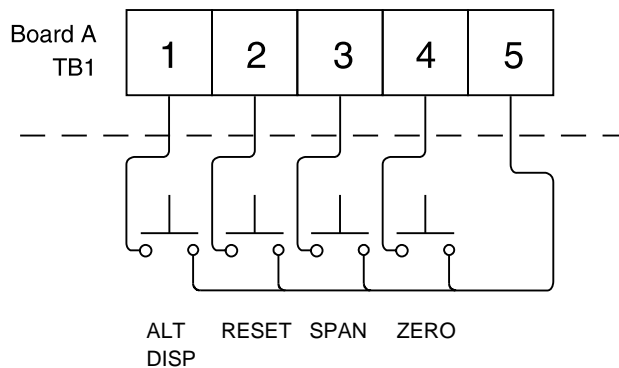

1. Relay contacts are rated for 5 A @ 250 V ac.
2. Remote pushbutton switches normally open style, supplied by Milltronics only on particular Compu-M arrangements.

REMOTE TOTALIZER

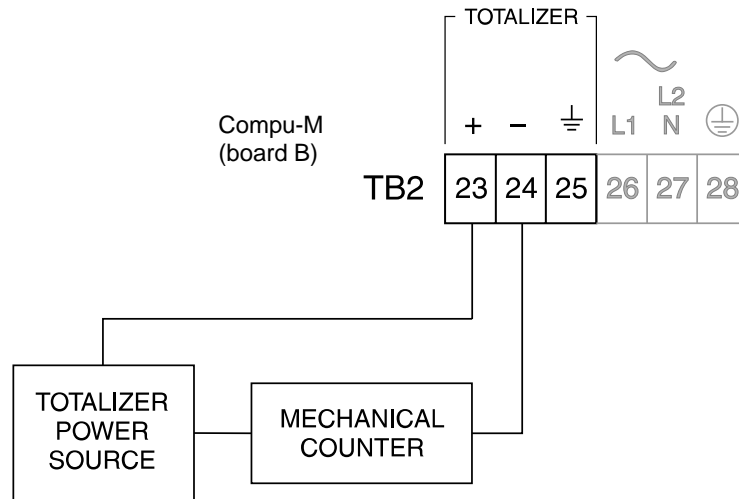

1. Refer to remote totalizer manufacturers instructions for wiring and power requirements.
2. If totalizer power is 24 V dc or less the remote totalizer wiring may be run in a common conduit with any combination of :
 - A) LVDT or Load cell wiring
 - B) Analog output wiring
 - C) Speed sensor wiring

POWER CONNECTIONS

AC Power

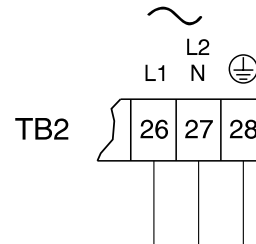
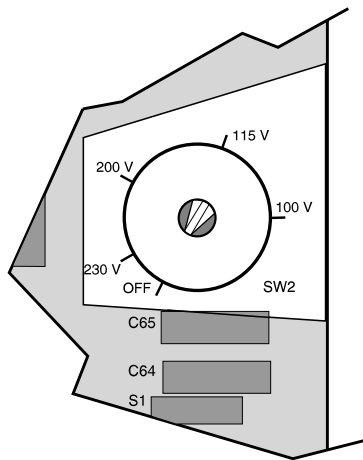

Voltage
Select

100 / 115 / 200 / 230 V
50 / 60 Hz 15 VA
select voltage via switch

Switch shown in 'Off' position.
Select appropriate voltage.

The equipment must be protected by a 15 A fuse or circuit breaker in the building installation.

A circuit breaker or switch in the building installation, marked as the disconnect switch, shall be in close proximity to the equipment and within easy reach of the operator.

Connect the Compu-M via terminal 28 to protective earth / ground.

DC Power

12 V dc Model

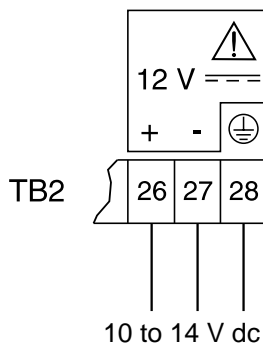

24 V dc Model

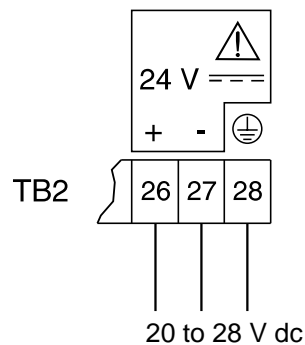

dc terminals shall be supplied from an SELV source in accordance with IEC-1010-1 Annex H.

PROGRAMMING

OPERATING MODES

The Compu-M has two selectable modes of operation: "Access" or "Run". In either mode, parameter values may be viewed, accepted or altered, zero and span calibrations may be initiated and the totalizer may be reset. However the level of access to these functions is determined by the security parameter P66. Attempting to perform a function outside of the access security level will result in a display message [E1].

The access mode is automatically assumed upon initial power up and upon completion of zero and span calibrations or Factoring (P9).

The run mode is the normal operating mode and may be selected by pressing "RUN" or "ALT DISP". In the run mode, the desired display mode is selected by pressing "ALT DISP" until the corresponding display mode indicator LED on the Compu-M front cover is illuminated.

All operator programmed information is maintained in non-volatile EEPROM memory and therefore is retained in the event of a power interruption. The Compu-M will return to the previous operating mode when power resumes.

The level of access security chosen may limit operator access to some of the following keypad functions.

KEYPAD

| <i>Button</i> | <i>Function</i> |
|------------------|--|
| "0"... "9" | numeric entries |
| "4" | increase analog mA output (P13 and P14 only) |
| "8" | decrease analog mA output (P13 and P14 only) |
| "." | decimal point |
| "_" | access mode: negative entry, run mode: activate/deactivate LCD backlight |
| "RUN" | enter the run mode, return to previously selected display mode |
| "PAR" | access parameter for entry or viewing |
| "ZERO" | activate zero calibration or view current zero count |
| "SPAN" | activate span calibration or view current span count |
| "ALT DISP" | access mode: enter the run mode, return to previously selected display mode run mode: scrolls through display modes, cancels Auto Scroll display (P21) |
| "RESET TOTAL" | reset local totalizer to zero (0) |
| "CLEAR" | clear display |
| "ENTER" | enter parameter number selected, display current parameter value, enter display value into selected parameter number, accept zero, or span calibration deviation |

PARAMETER ENTRY

Specific application information must be entered into the appropriate Compu-M memory locations. These locations are identified by a *parameter number* (P#). The information entered is referred to as a *parameter value* (value). To enter specific application information the operator accesses the desired parameter, views the parameter value on the LCD display, and then accepts or alters the current parameter value.

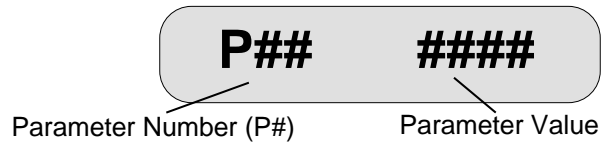

DIRECT PARAMETER ACCESS

To directly access any parameter, press "PAR". If [P] is presently displayed, the Compu-M is currently prompting the operator to enter a parameter number. Enter the desired parameter number as listed on the Compu-M front cover or in Parameters. If [P#] is displayed the Compu-M is currently in the access mode.

e.g. press "PAR"

 [P] will be displayed, P01 is desired

 press "0" and then "1"

 [P01] will be displayed

AUTOMATIC PARAMETER ACCESS (APA)

Values for parameters: P01, 02, 0, 1, 2, 3, 4, 5, 6, 7 must be entered to complete basic programming. Upon accessing any of these parameters, pressing "ENTER" will cause the Compu-M to enter the current parameter value displayed and automatically access the next parameter in this loop.

e.g. [P01 1] is displayed

 press "ENTER"

 [P02 1] will be displayed

VIEW PARAMETER VALUES

To view a parameter's contents, access the desired parameter as previously described. Automatically accessed parameter values are immediately displayed. Direct accessed parameters will require "ENTER" to be pressed in order to view the current value.

e.g. [P50] is displayed

 press "ENTER"

 [P50 #] will be displayed

ALTERING PARAMETER VALUES

With [P# #] displayed, the operator may elect to change the contents of the selected parameter. Key in the desired value and press "ENTER". If the operator fails to press "ENTER" after keying in a new parameter value, the original value will be retained. If the parameter value altered was in the APA loop pressing "ENTER" again will cause the next parameter in the loop to be accessed.

e.g. [P02 1] is displayed, option 2 is desired

press "2"

[P02 2] is displayed

press "ENTER"

PARAMETER RESET

This feature returns the Compu-M memory to factory settings. The implementation of a reset: requires total parameter re-entry, zero and span recalibration, and resets the local totalizer to 0. Refer to Parameter Listing P99 for details.

DISPLAY MESSAGES

| <i>Display</i> | <i>Message</i> | <i>Comment</i> |
|----------------|----------------------------|--|
| [E1] | security code required | refer to P66 |
| [E2] | total registration too low | enter a higher value in P2 or P3 |
| [E3] | zero out of range | zero deviation is greater than limit as set by P-25 |
| [E4] | span out of range | deviation from initial span is greater than 12.5% of span |
| [E5] | parameter not entered | a required parameter was not entered during the initial programming |
| [E6] | zero calibration required | perform a zero calibration. By-pass by pressing "CLEAR " "ENTER", if a zero recalibration has been performed recently. |
| [E7] | span calibration required | perform a span calibration |
| [E8] | entry error | invalid parameter number entered invalid parameter value entered |
| [E9] | auto zero out of range | self initiated auto zero deviation from the last routine zero is greater than 2% but less than 12.5% of span |



APPLICATIONS

BELT SCALE APPLICATION

OPERATION

Input Signals

The Compu-M supplies the excitation for the belt scale load cell(s). The load cell(s) produce an analog mV signal which is proportional to the load on the scale.

Excitation is also provided for a speed sensor. If used, the speed sensor produces a digital signal at a frequency which is proportional to belt speed.

In cases where a speed sensor is not used, the Compu-M simulates a speed sensor input representing a constant belt speed which is operator adjustable to suit the particular application.

If the Compu-M is to be utilized with a belt scale that is installed on a variable incline conveyor (such as a stacker), an Incline Compensator should be used. The Incline Compensator automatically corrects the load cell(s) signal variation caused by a change in conveyor incline.

Signal Processing

The Compu-M utilizes the load and speed signals to produce an internal rate signal. Utilizing advanced microprocessor technology the Compu-M converts the internal rate signal to provide; display, analog output, remote totalizer contact and rate alarm.

Display Modes

Four operator selectable display modes are available (RATE, TOTAL, LOAD or SPEED). The modes can be scrolled manually by pressing 'ALT DISP', or the Rate and Total automatically by setting P21, auto scroll display.

The Rate, Load, Speed displays, in operator selectable engineering units, are stabilized by the level of damping programmed (P11).

The Rate Display represents the rate at which material is currently conveyed.

The Total Display represents the total amount of material which has passed over the belt scale since the last Compu-M (local) totalizer reset. The operator may reset this display to zero (0) at any time, depending on the access security level programmed, by pressing "**RESET TOTAL**", "**CLEAR**".

The Load Display represents the force currently applied to the belt scale by the weight of the material on the belt.

The Speed Display represents the current belt speed.

Analog mA Output

This D.C. current output is proportional to the current rate of material throughput and may be utilized for operating external process monitoring and/or process control equipment. The minimum output corresponding to minimum (usually 0) rate is user selectable (P12) for 0 or 4 ma. The maximum output corresponding to maximum desired rate is 20mA. The analog mA output may be stabilized by the damping values entered in P11 or P18.

Remote Totalizer Contact

The Compu-M provides a relay contact closure which may be utilized to operate an external device such as a remote totalizer. The on-time duration of the relay contact closure is operator selectable (P16) to suit the external device connected.

Alarm

The Compu-M provides a programmable relay for alarm (P20) on material rate, belt speed or auto zero out of range. If enabled, the relay is energized under normal operation. Under alarm condition, the relay is de-energized and the display flashes. Upon return to normal operation, the alarm state is cleared and the relay energized. If the relay is programmed for auto zero the alarm is in effect until an auto zero within range occurs, when a calibration is initiated or when the rate exceeds 12% of design.

The relay contacts are accessed via board A, TB2.

INITIAL START UP

When working on a belt scale, ensure that the conveyor is stopped and locked out.

Once installation, interconnection and internal checks have been completed, apply power to the Compu-M. The display should read, [P].

Reset

Prior to programming, a Compu-M memory reset should be performed.

select P99

press "ENTER"

[P99 0] displayed

press "9" for Master Reset

[P99 9] displayed

press "ENTER", when the memory reset is complete,

[P] displayed.

The Compu-M memory has now been cleared of any undesired data and all parameters have been reset to factory values.

Dual Load Cell Balance

Prior to the initial start up of a dual load cell belt scales*, verify the load cell signal balance. This procedure is also required should one or both load cells be removed and reinstalled or replaced.

Identify load cell "A" and load cell "B". Load cell "A" is on the left hand side when viewing a Milltronics scale from the tail pulley.

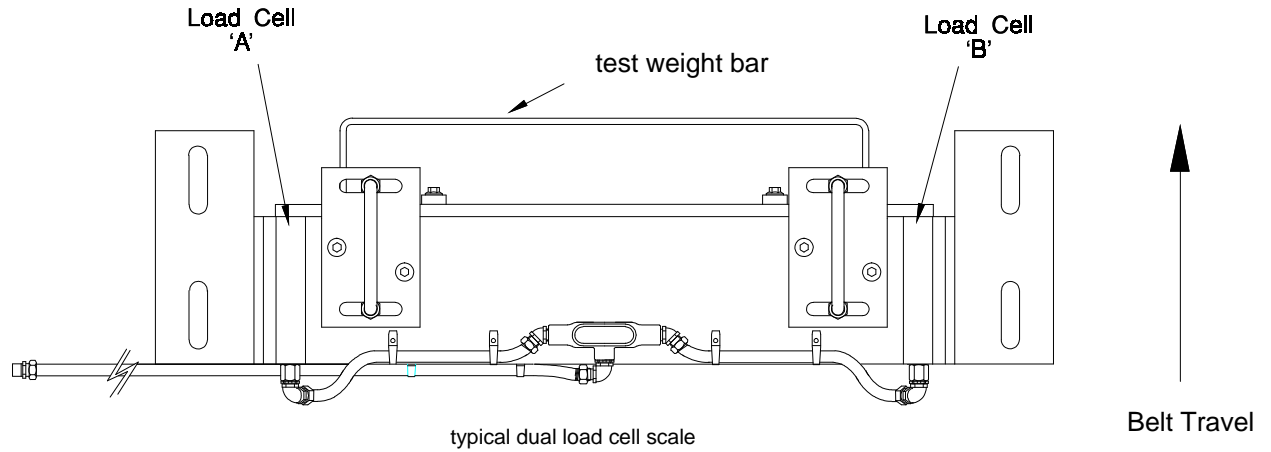

* **MMI - 2 Belt Scale Note**

- » When balancing the load cells, a separate test weight is applied to each MSI suspension. The weights are moved in unison during the balancing procedure.

With the conveyor stopped and locked out, lift the belt off the weighing idlers if possible. Suspend a test weight on the load cell B side of the scale test weight bar. Ensure Compu-M board B switch SW 1 is in the **CLOSED** position.

Except where otherwise indicated in the following procedure, Compu-M board B switch SW1 must be kept in the closed position at all times.

Apply power to the Compu-M,

[P] displayed

select P91

[P91] displayed

press "ENTER"

[P91 #####] displayed

press "ENTER"

[P92] displayed

Set switch SW 1 to the **OPEN** position.

press "ENTER"

[P92 #####] displayed

press "ENTER"

[P93] displayed

Move the test weight from the load cell B side to the load cell A side of the test weight bar.
Leave switch SW 1 in the **OPEN** position.

press "ENTER"

[P93 #####] displayed

press "ENTER"

[P94] displayed

Return switch SW 1 to the **CLOSED** position.

press "ENTER"

[P94 #####] displayed

press "ENTER"

[P95 #####] displayed

Adjust the Compu-M, board B, A BAL potentiometer (P3) as required until the displayed value equals 0 ± 5 counts.

Remove the test weight and ensure Compu-M board B switch SW1 is in the **CLOSED** position.

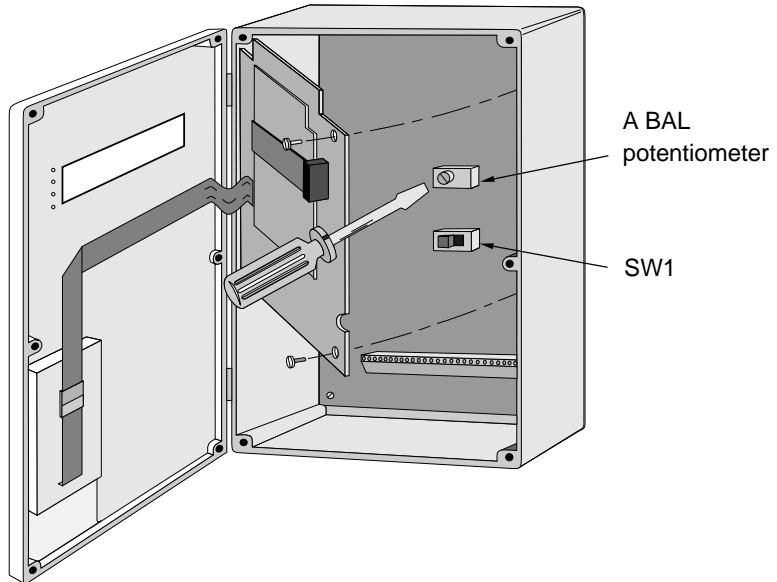

**Where the dual load cell balance procedure is performed on a previously calibrated system, a new zero and span calibration must be performed.
Refer to APPLICATIONS/Recalibration.**

Programming and Calibration

The following parameters are in the Automatic Parameter Access (APA) loop. Press "ENTER" once to accept the current parameter value and proceed to the next parameter. To alter a parameter value, key in the new value and press "ENTER". Press "ENTER" again to advance to the next parameter.

with [P] displayed

press "ENTER"

[P01 1] displayed, Belt Scale Application

press "ENTER"

[P02 1] displayed, Load Cell Input

press "ENTER"

[P0 1] displayed, Rate Units = MTPH

| | |
|---------------|----------|
| key in value, | 1 = MTPH |
| | 2 = KG/H |
| | 3 = LTPH |
| | 4 = STPH |
| | 5 = LB/H |

press "ENTER"

[P1 0.000] displayed, Design Rate = 0

key in value, (Rate from Design Data Sheet)

press "ENTER"

[P2 1.000] displayed, Local Totalizer Update = every 1 unit.

key in value, (refer to Parameters, P2)

press "ENTER"

[P3 1.000] displayed, Remote Totalizer Update = every 1 unit.

key in value, (refer to Parameter Listing, P3)

press "ENTER"

[P4 0.000] displayed, Belt Speed = 0

key in value, (Belt Speed from Design Data Sheet)

press "ENTER"

[P5 #####] displayed, Speed Constant (refer to Parameter Listing)

key in value, (Speed Constant, only if a speed sensor is utilized)

press "ENTER"

[P6 0.000] displayed, Belt Length = 0

key in value, (Belt Length, as measured or from Design Data Sheet)

press "ENTER"

[P7 #####] displayed, Test Load = 100% Design Load

key in value, (Test Load, from Design Data Sheet. Refer to the associated belt scale instruction manual.)

press "ENTER"

Zero Calibration

If the actual belt speed is 10% or less than the Design Belt Speed (P4), the calibration will be aborted. [oF 0] will be displayed.

Run the empty belt at normal operating speed for some time to limber up the belt (at least 10 minutes).

press "ZERO"

[oo 0] displayed

press "ENTER", all 4 display mode LED's will be illuminated,

[oo #####] displayed, wait (time dependent on value of P30)

[od 0.000] displayed, Zero Deviation

press "ENTER"

[oC #####] displayed, Initial Zero Reference Count

Span Calibration

If the actual belt speed is 10% or less than the Design Belt Speed (P4), the calibration will be aborted. [SF 0] will be displayed.

Suspend the Test Weight(s) from the scale calibration weight bracket or place the test chain on the belt. Refer to the associated belt scale instruction manual.

Run the conveyor at normal operating speed.

press "SPAN"

[SP 0] displayed

press "ENTER", all 4 display mode LED's will be illuminated and

[SP #####] displayed, wait (time dependent on the value of P30)

[Sd 0.0000] displayed, Span Deviation

press "ENTER"

[SC #####] displayed, Initial Span Reference Count

Automatic Parameter Access (APA) programming complete. Parameter programming outside of the APA loop must be directly accessed.

ie: Press "PAR", press "#", press "ENTER", key in new value, press "ENTER".

Belt Speed Compensation

Run the belt empty for 5 - 10 minutes ensuring that it is completely empty. Select the Belt Speed Display Mode by pressing "ALT DISP" until the *SPEED* Display Mode Status LED on the Compu-M front cover is illuminated. If the displayed speed equals the Design Speed, proceed to the optional material test. If not, with the belt stopped, measure a section of the belt. Run the belt again. Measure the time period required for the measured length of belt to pass.

measured speed = $\frac{\text{belt length}}{\text{time}}$ (engineering units as selected in P4 to be used)

select P17

press "ENTER"

[P17 #] displayed, Dynamic Belt Speed

key in value, (measured belt speed)

press "ENTER"

[P17 #] displayed, Design Belt Speed

If the Compu-M Constant Speed Input is jumpered the preceding steps will have altered the Design Speed (P4). Record the new P4 value on the Programming Chart.

If the Compu-M Speed Input is supplied by a Speed Sensor the preceding steps will have altered the Speed Constant (P5). Record the new P5 value on the Programming Chart.

In either case above the Compu-M speed display now equals the Actual Speed.

BASIC CALIBRATION COMPLETE
PRESS "RUN" TO ENTER THE RUN MODE FOR NORMAL OPERATION

Optional Material Test

Material tests are performed to verify the accuracy of the Compu-M span calibration. If the material tests indicate a repeatable calibration deviation exists, a Manual Span Adjust (P8) is performed. This procedure automatically alters the Span calibration and adjusts the Test Load (P7) value accordingly. Subsequent span recalibration utilizing the Test Weight or Test Chain will provide more accurate calibration results.

1. Run the belt empty.
2. Perform a zero calibration.
3. Record the Compu-M Total Display, (start value).
4. Press "**RUN**".
5. Run material on the belt for 5 minutes minimum. (Ensure the test weight/chain is removed).
6. Stop the material feed and run the conveyor empty.
7. Record the Compu-M Total Display, (stop value).
8. Subtract the start value from the stop value to determine the Compu-M Total.
9. Weigh the material sample, (if the actual material weight is not already known).
10. Calculate the span error...

$$\% \text{ Span Error} = \frac{\text{Compu-M Total} - \text{Material Sample Weight}}{\text{Material Sample Weight}} \times 100$$

If the span error is within the accuracy requirements of the system, the material test was a success and normal operation may be resumed.

If the span error is not acceptable, repeat steps 1 through 10 to verify the span error is repeatable. If the span error of the second test is considerably different from the span error of the first test (for no apparent reason), consult Milltronics or your local distributor.

If the span error is repeatable (the results of both material tests are similar), proceed as follows.

select P8 (Manual Span Adjust)

[P8 A] displayed

key in the calculated % span error (if the result was negative, enter a negative value).

press "**ENTER**"

[P7 ###] displayed, (adjusted Test Load value, copy this new value onto the Programming Chart)

Repeat steps 1 through 10. The span error should now be within the system accuracy requirements.

Manual Span Adjust complete.

Additional Performance Enhancement

After performing the initial span or after running a material test P10, P11, P12, P13, P14, P16, P17, and P18 may be altered to enhance the display readings and rate output of the Compu-M. These direct access parameters are explained in detail in, Parameters.

PROGRAMMING CHART - EXAMPLE (BELT SCALE)

PROGRAMMING CHART

| | | |
|------------------------------|------------|---|
| P01 MODE: | [1] | 1 = belt scale, 2 = flowmeter |
| P02 OPERATION: | [1] | 1 = load cell, 2 = LVDT |
| P0 UNITS: | [1] | rate display, 1= MTPH, 2 = KG/H, 3 = LTPH, 4 = STPH, 5 = LB/H |
| P1 DESIGN RATE: | [2000] | from design data sheet |
| P2 LOCAL TOTAL: | [1] | registration multiplier, refer to parameters |
| P3 REMOTE TOTAL: | [1] | registration multiplier, refer to parameters |
| * P4 BELT SPEED: | [1.5] | from design data sheet m/sec or ft/min. |
| * P5 SPEED CONSTANT: | [278.5] | from design data sheet |
| * P6 BELT LENGTH: | [10] | from design data sheet or as measured, m or ft |
| P7 TEST LOAD/RATE: | [259.26] | KG/M or LB/FT (belt scales) MTPH,KG/H,LTPH,STPH or LB/H (flowmeters) |
| ZERO CALIBRATION | [####] | observed Initial zero referencecount |
| SPAN CALIBRATION | [#####] | observed Initial span reference count |
| P8 MANUAL SPAN ADJUST: | [-3.3] | material test % span error |
| P9 FACTORING: | [0] | test weight correction 0 = no, 1 = yes |
| P10 TOTAL DROPOUT: | [5] | totalizer cutoff point % |
| P11 DAMPING: | [12] | local display and rate output, from 1 to 9999 |
| P12 RATE OUTPUT: | [1] | 1 = 4-20 mA, 2 = 0-20 mA |
| P16 TOTALIZER RELAY: | [3] | on-time closure duration, from 1 to 9 |
| * P17 SPEED CONSTANT ADJUST: | [###] | actual belt speed m/sec or ft/min |
| P18 RATE OUTPUT DAMPING: | [17] | if other than P11 value, from 0 to 9999 |
| P20 ALARM RELAY: | [0] | 0 = off, 1 = rate set point: Low [] High [] 2 = fixed rate 3 = auto zero * 4 = speed set points: Low [] High [] |
| P21 AUTO SCROLL DISPLAY | [0] | 0 = off, 1 = alternating |
| ▲P24 LINEARIZER | [0] | 0 = disabled 1 = enabled L1 [] L2 [] L3 [] L1c [] L2c [] L3c [] |
| P25 ZERO LIMIT | [0] | 0 = 12.5%, 1 = 2% |
| P30 CALIBRATION DURATION: | [3] | utilized for zero or span calibrations, from 1 to 99 |
| P67 DIRECT ZERO ENTRY | [0] | 0 = disabled 1 = enabled |
| P68 DIRECT SPAN ENTRY | [0] | 0 = disabled 1 = enabled |

* parameter applicable to belt scale applications only, P01 = 1

▲ parameter applicable to flowmeter applications only, P01 = 2

RECALIBRATION

Design Changes

Some parameters interact with others. After altering a parameter value, check all other parameter values. The Compu-M may have altered one or more interacting parameters automatically. Record all parameter value changes on the Design Data Sheet and Programming Chart for future reference.

Recalibration

To maintain Belt Scale accuracy, periodic zero and span recalibration is recommended. Recalibration requirements are highly dependent upon the severity of the application operating conditions. Perform frequent checks initially, then as time and experience dictate, the frequency of these checks may be reduced. Always record any deviations experienced for future reference.

Routine Zero

To perform a routine zero recalibration, run the empty belt for 5 - 10 minutes.

press "ZERO"

[oo #####] displayed, Current Zero Count

press "ENTER"

[oo #####] displayed, wait (time dependent upon the value of P30)

[od #####] displayed, Zero Deviation in %

press "ENTER"

[oC #####] displayed, New Zero Count, zero complete

If [oo E3] displayed; routine zero attempt aborted, zero deviation is greater than the limit as set by P-25.

The [E3] Display Message normally indicates a mechanical problem. Investigate the cause of the deviation and make the necessary correction. Retry the zero calibration. If the deviation is determined to be acceptable, perhaps because of intended mechanical changes to the system, set P77 to 1 to invoke a new " Initial Zero Calibration Reference". Any future deviation will be based on this new Zero.

Initial Zero

select P77

press "ENTER"

[P77 0] displayed

press "1"

press "ENTER"

[P77 1] displayed

press "ENTER"

[oO #####] displayed, wait (time dependent upon the value of P30)

[oD 0.000] displayed

press "ENTER"

[oC #####] displayed, New Zero Count, zero calibration complete

Direct Zero Entry

Direct entry is intended for use when replacing software or hardware and it is not convenient to perform an initial zero at that time.

select P67

press "ENTER"

[P67 0] displayed

press "1"

[P67 1] displayed

press "ENTER"

[Pc 0.] displayed e.g. value '0' after a P99 reset

enter the recorded zero reference of previous zero (#####)

press "ENTER"

[oC #####] displayed, new zero count, entry complete

Routine Span

To perform a routine span recalibration, stop the conveyor belt and suspend the test weight from the scale calibration weight bracket or place the test chain on the belt. Refer to associated scale manual.

Run the belt, empty (except for the test chain, if used) at normal operating speed

press "SPAN"

[SP #####] displayed, Current Span Count

press "ENTER"

[SP #####] displayed, wait (Time dependent on the value of P30)

[Sd #####] displayed, Span Deviation in %

press "ENTER"

[SC #####] displayed, New Span Count, span complete

If [SP E4] displayed; routine span attempt aborted, deviation from initial span calibration was greater than 12.5% of span.

An [E4] Display Message normally indicates a mechanical problem. Investigate the cause of the deviation and make the necessary correction. Retry the span calibration.

If the deviation is determined to be acceptable, perhaps as the result of an intended mechanical change to the system, set P88 to 1 to invoke a new " Initial Span Calibration Reference". Further deviations will be based on this new Span.

Initial Span

select P88

press "ENTER"

[P88 0] displayed

press "1"

press "ENTER"

[P88 1] displayed

Press "ENTER"

[SP #####] displayed, wait (time dependent on the value of P30)

[Sd 0.000] displayed

press "ENTER"

[SC #####] displayed, New Span Count, span calibration complete

Perform a material test, if desired, to verify the new calibration accuracy.

Direct Span Entry

Direct entry is intended for use when replacing software or hardware and it is not convenient to perform an initial span at that time.

select P68

press "ENTER"

[P68 0] displayed

press "1"

press "ENTER"

[P68 1] displayed

press "ENTER"

[Pc 0.] displayed e.g. value after a P99 reset

enter the recorded span reference count of the previous span (#####)

press "ENTER"

[SC #####] displayed, new span count, entry complete

Self Initiated Auto Zero

Where frequent minor zero deviations are expected, the Compu-M self initiated auto zero feature may be utilized to perform an automatic zero calibration whenever the material flow ceases.

Connect a dry contact activated by a material prefeed control device such as a prefeed motor, material control gate, or valve to board B 1TB-1 and 2 of the Compu-M. The contact must be closed while the material prefeed is stopped.

While this contact is closed and after sensing an empty running belt the Compu-M will perform an auto zero. If the difference between the auto zero and the last operator initiated (routine) zero calibration is less than 2% of the design Rate (P1), the Compu-M will accept the auto zero results.

If the difference between the auto zero and the last routine zero is greater than 2% of the design Rate, the Compu-M will display [E9 - auto zero out of range] temporarily, reject the results of the auto zero attempt and then resume normal operation.

If the alarm relay is set for auto zero (P20 = 3) , the relay is de-energized and the display flashes. The alarm is in effect until an 'auto zero' within range occurs, when a calibration is initiated, or when the rate exceeds 12% of design.

If the Compu-M displays [E9] after repeated auto zero attempts, the operator should perform a routine zero calibration. Future auto zero attempts will be referenced to this new zero calibration.

The Compu-M will continue to perform auto zero calibrations until the prefeed activated contact connected to TB1-1 and 2 is open. Any material totalized during a self initiated auto zero is added to the Compu-M total and the remote total. The analog mA output will respond to any material measured during a self initiated auto zero.

APPLICATIONS (Cont'd)

SOLIDS FLOWMETER APPLICATION

OPERATION

Input Signals

The Compu-M supplies the excitation for the flowmeter transducing element, (LVDT or load cell). Material flowing through the flowmeter is directed toward a sensing plate. The sensing plate is designed to deflect horizontally proportional to material flow. This horizontal deflection is applied to the transducing element which produces a signal proportional to material flow.

Signal Processing

The Compu-M utilizes the material flow signal to produce an internal rate signal. Utilizing advanced microprocessor technology, the Compu-M converts the internal rate signal to provide display, analog output, remote totalizer contact and rate alarm.

Display Modes

Two operator selectable display modes are available (RATE or TOTAL). The modes can be scrolled manually by pressing 'ALT DISP' or automatically by setting P21, auto scroll display.

The Rate Display represents the rate at which material is currently flowing through the system. This display, in operator selectable engineering units, may be stabilized by the level of damping programmed, (P11).

The Total Display represents the total amount of material which has passed through the flowmeter since the last Compu-M (local) totalizer reset. The operator may reset this display to zero (0) at any time, depending upon the access security level programmed, by pressing "**RESET TOTAL**", "**CLEAR**".

Analog mA Output

This DC current output is proportional to the current rate of material flow and may be utilized for operating external process monitoring and/or process control equipment. The minimum output corresponding to minimum (usually 0) flow is user selectable (P12) for 0 or 4 ma. The maximum output corresponding to maximum desired material flow is 20mA. The analog mA output is stabilized by the damping values entered in P11 or P18.

Remote Totalizer Contact

The Compu-M provides a relay contact closure which may be utilized to operate an external device such as a remote mounted totalizer. The on-time duration of the relay contact closure is operator selectable (P16) to suit the external device connected.

Alarm

The Compu-M provides a programmable relay for alarm (P20) on material rate, or auto zero out of range. If enabled, the relay is energized under normal operation. Under alarm condition, the relay is de-energized and the display flashes. Upon return to normal operation, the alarm state is cleared and the relay energized. If the relay is programmed for auto zero the alarm is in effect until an auto zero within range occurs, when a calibration is initiated or when the rate exceeds 12% of design.

The relay contacts are accessed via board A, TB2.

TEST RATE

The Test Rate (P7) is the flowrate chosen for calibration purposes. The *test rate* is a simulated material flowrate created by attaching a weight in such a manner as to apply a horizontal force to the flowmeter sensing plate. This weight is referred to as the *test weight*. Refer to the associated flowmeter instruction manual for assistance with the calculation and application of the test weight required to produce a desired test rate, or conversely, the test rate produced by a known test weight.

INITIAL START UP

**When working on a flowmeter, ensure that the material
prefeed has been stopped and locked out.**

Once installation, interconnection and internal checks have been completed, apply power to the Compu-M. The display should read, [P].

Reset

Prior to programming, a Compu-M memory reset should be performed.

select P99

press "ENTER"

[P99 0] displayed

press "9" for Master Reset

[P99 9] displayed

press "ENTER", memory reset complete

[P] displayed.

The Compu-M memory has now been cleared of any undesired data and all parameters have been reset to factory values.

Programming And Calibration

The following parameters are in the Automatic Parameter Access (APA) loop. Press "**ENTER**" once to accept the current parameter value and proceed to the next parameter. To alter a parameter value, key in the new value and press "**ENTER**". Press "**ENTER**" again to advance to the next parameter.

with [**P**] displayed

press "**ENTER**"

[**P01 1**] displayed, Belt Scale Application

press "**2**"

press "**ENTER**"

[**P01 2**] displayed, Flowmeter Application

press "**ENTER**"

[**P02 1**] displayed, Load Cell Input

key in value, 1 = Load Cell
2 = LVDT

press "**ENTER**"

[**P0 1**] displayed, Rate Units = MTPH

key in value, 1 = MTPH
2 = KG/H
3 = LTPH
4 = STPH
5 = LB/H

press "**ENTER**"

[**P1 0.000**] displayed, Design Rate = 0

key in value, Rate from Design Data Sheet or Order Acknowledgement

press "**ENTER**"

[**P2 1.000**] displayed, Local Totalizer Update = every 1 unit.

key in value, (refer to Parameters, P2)

press "**ENTER**"

[**P3 1.000**] displayed, Remote Totalizer Update = every 1 unit.

key in value, (refer to Parameters, P3)

press "**ENTER**"

[**P7 #####**] displayed, Test Rate, 100% of Design Rate

key in value, from Design Data Sheet or refer to the associated flowmeter instruction manual.

press "**ENTER**"

Zero Calibration

With the material flow stopped and Test Weight removed,

press "**ZERO**"

[**oo 0**] displayed

press "**ENTER**", all 4 display mode LED's will be illuminated,

[**oo #####**] displayed momentarily then,

[**od 0.000**] displayed, Zero Deviation

press "**ENTER**"

[**oC #####**] displayed, Initial Zero Reference Count

Span Calibration

Apply the Test Weight as described in the associated flowmeter instruction manual.

press "**SPAN**"

[**SP 0**] displayed

press "**ENTER**", all 4 display mode LED's will be illuminated and

[**SP #####**] displayed momentarily then,

[**Sd 0.0000**] displayed, Span Deviation

press "**ENTER**"

[**SC #####**] displayed, Initial Span Reference Count

Remove the test weight.

BASIC CALIBRATION COMPLETE
PRESS "**RUN**" TO ENTER THE RUN MODE FOR NORMAL OPERATION

Automatic Parameter Access (APA) programming complete. Further programming, if desired, to enhance the performance of the Compu-M requires parameter programming outside of the APA loop. These parameters must be directly accessed.

ie. Press "**PAR**", press "**#**", press "**ENTER**", key in new value, press "**ENTER**".

Optional Material Test

Material tests are performed to verify the accuracy of the Compu-M span calibration. If the material tests indicate a repeatable calibration deviation exists, a Manual Span Adjust (P8) is performed. This procedure automatically alters the Span calibration and adjusts the Test Rate (P7) value accordingly. Subsequent span recalibration utilizing the Test Weight will provide more accurate calibration results.

1. Stop the material flow.
2. Perform a zero calibration.
3. Record the Compu-M Total Display, (start value).
4. Press **"RUN"**.
5. Run material through the flowmeter for 5 minutes minimum. (Ensure the test weight is removed).
6. Stop the material flow.
7. Record the Compu-M Total Display, (stop value).
8. Subtract the start value from the stop value to determine the Compu-M Total.
9. Weigh the material sample, (if the actual material weight is not already known).
10. Calculate the span error...

$$\% \text{ Span Error} = \left(\frac{\text{Compu-M Total} - \text{Material Sample Weight}}{\text{Material Sample Weight}} \right) \times 100$$

If the span error is within the accuracy requirements of the system, the material test was a success and normal operation may be resumed.

If the span error is not acceptable, repeat steps 1 through 10 to verify the span error is repeatable. If the span error of the second test is considerably different from the span error of the first test (for no apparent reason), consult Milltronics or your local distributor.

If the span error is repeatable (the results of both material tests are similar), proceed as follows.

select P8 (Manual Span Adjust)

[P8 A] displayed

key in the calculated % span error (if the result was negative, enter a negative value).

press **"ENTER"**

[P7 ###] displayed, (adjusted Test Rate value, copy this new value onto the Programming Chart)

Repeat steps 1 through 10. The span error should now be within the system accuracy requirements.

Manual Span Adjust complete.

Linearization

Where the flowrate reported by the Compu-M is non-linear due to material flow characteristics, compensation is achieved by enabling and programming the linearization parameter, P24.

To verify that the cause of the non-linearity is not mechanical:

- stop the process
- apply the various test weights to the flowmeter to verify mechanical linearity. If the reported rate is non-linear, a mechanical problem is indicated. Refer to the associated flowmeter manual.

If non-linearity due to material flow characteristics is still suspect, apply linearization.

- perform a zero calibration
- perform a span calibration at 90 to 100% of design rate
- perform material tests at 90 to 100% of design rate
- perform a manual span adjustment if required
- perform material tests at 1 to 3 intermediary flowrates where compensation is required.

Up to three compensation points, at least 10% apart, can be programmed between 10 and 90% of the design rate value, P1, in the units of P0. The points should be programmed at operating flowrates where non-linearity is evidenced.

- calculate the percentage compensation for each flowrate tested.

$$\% \text{ compensation} = \left(\frac{\text{actual weight} - \text{totalized weight}}{\text{totalized weight}} \right) \times 100$$

example: a non-linearity with respect to the ideal response exists in a flowmeter application with a design rate of 100 TPH. After performing a zero and a span calibration at 100% of the design rate, followed by material tests and manual span adjustments, 5 minute material tests were performed at 30, 55, and 80% of the design rate, as indicated on the Compu-M. The following data was tabulated. (Example is exaggerated for emphasis.)

| Compu-M flowrate | material test actual mass (tons) | Compu-M reading (tons) | compensation* (%) |
|------------------|----------------------------------|------------------------|-------------------|
| 30% | 2.1 | 2.50 | -16 |
| 55% | 5.0 | 4.85 | 9.2 |
| 80% | 6.1 | 6.67 | -8.5 |

*calculation example % compensation = $\left(\frac{2.1 - 2.50}{2.50} \right) \times 100$
 = -16

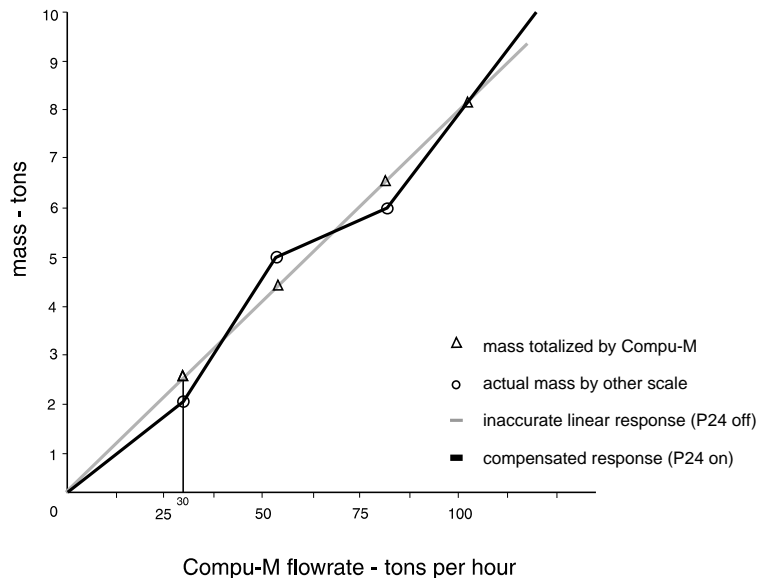

select **P24**
press "ENTER"
[P24 0] displayed
press "1"
press "ENTER"
[P24 1] displayed
press "ENTER"
[L1 0.] displayed
press "30"
press "ENTER"
Press "ENTER"
[L1c 0.00] displayed
press "-16"
press "ENTER"
[L1c -16.0]
press "ENTER"
[L2 0.00]
. . .
L3c 0.00]
press "- 8.5"
press "ENTER"
[L3c - 8.5]
press "ENTER"
[L1 30.0] displayed

Upon returning to Run Mode , compensation is active until P24 is set to 0.

PROGRAMMING CHART - EXAMPLE (FLOWMETER)

PROGRAMMING CHART

| | | |
|------------------------------|-----------|---|
| P01 MODE: | [2] | 1 = belt scale, 2 = flowmeter |
| P02 OPERATION: | [2] | 1 = load cell, 2 = LVDT |
| P0 UNITS: | [5] | rate display, 1= MTPH, 2 = KG/H, 3 = LTPH, 4 = STPH, 5 = LB/H |
| P1 DESIGN RATE: | [1200] | from design data sheet |
| P2 LOCAL TOTAL: | [1] | registration multiplier, refer to parameters |
| P3 REMOTE TOTAL: | [1] | registration multiplier, refer to parameters |
| * P4 BELT SPEED: | [] | from design data sheet m/sec or ft/min. |
| * P5 SPEED CONSTANT: | [] | from design data sheet |
| * P6 BELT LENGTH: | [] | from design data sheet or as measured, m or ft |
| P7 TEST LOAD/RATE: | [1000] | KG/M or LB/FT (belt scales) MTPH,KG/H,LTPH,STPH or LB/H (flowmeters) |
| ZERO CALIBRATION | [#####] | observed Initial zero referencecount |
| SPAN CALIBRATION | [#####] | observed Initial span reference count |
| P8 MANUAL SPAN ADJUST: | [6.6] | material test % span error |
| P9 FACTORING: | [0] | test weight correction 0 = no, 1 = yes |
| P10 TOTAL DROPOUT: | [5] | totalizer cutoff point % |
| P11 DAMPING: | [12] | local display and rate output, from 1 to 9999 |
| P12 RATE OUTPUT: | [1] | 1 = 4-20 mA, 2 = 0-20 mA |
| P16 TOTALIZER RELAY: | [3] | on-time closure duration, from 1 to 9 |
| * P17 SPEED CONSTANT ADJUST: | [] | actual belt speed m/sec or ft/min |
| P18 RATE OUTPUT DAMPING: | [17] | if other than P11 value, from 0 to 9999 |
| P20 ALARM RELAY: | [0] | 0 = off, 1 = rate set point: Low [] High [] 2 = fixed rate 3 = auto zero * 4 = speed set points: Low [] High [] |
| P21 AUTO SCROLL DISPLAY | [0] | 0 = off, 1 = alternating |
| ▲P24 LINEARIZER | [0] | 0 = disabled 1 = enabled L1 [] L2 [] L3 [] L1c [] L2c [] L3c [] |
| P25 ZERO LIMIT | [0] | 0 = 12.5%, 1= 2% |
| P30 CALIBRATION DURATION: | [3] | utilized for zero or span calibrations, from 1 to 99 |
| P67 DIRECT ZERO ENTRY | [0] | 0 = disabled 1 = enabled |
| P68 DIRECT SPAN ENTRY | [0] | 0 = disabled 1 = enabled |

* parameter applicable to belt scale applications only, P01 = 1
 ▲ parameter applicable to flowmeter applications only, P01 = 2

Additional Performance Enhancement

After performing the initial span calibration or after running a material test P10, P11, P12, P13, P14, P16, and P18 may be altered to enhance the display readings and analog mA output. These direct access parameters are explained in detail in Parameters.

RECALIBRATION

Design Changes

Some parameters interact with others. After altering a parameter value check all other parameter values. The Compu-M may have altered one or more interacting parameters automatically. Record all parameter value changes on the Design Data Sheet and Programming Chart for future reference.

Recalibration

To maintain Flowmeter accuracy, periodic zero and span recalibration is recommended. Recalibration requirements are highly dependent upon the severity of the application operating conditions. Perform frequent checks initially, then as time and experience dictate, the frequency of these checks may be reduced. Always record any deviations experienced for future reference.

Routine Zero

To perform a routine zero recalibration, ensure the material flow is stopped and the prefeed is locked out.

press "ZERO"

[oo #####] displayed, Current Zero Count

press "ENTER"

[oo #####] displayed momentarily then,

[od #####] displayed, Zero Deviation in %

press "ENTER"

[oC #####] displayed, New Zero Count, zero complete

If [oo E3] displayed, routine zero attempt aborted, zero deviation is greater than the limit as set by P-25.

The [E3] Display Message normally indicates a mechanical problem. Investigate the cause of the deviation and make the correction necessary. Retry the zero calibration.

If the deviation is determined to be acceptable, perhaps as the result of an intended mechanical change to the system, set P77 to 1 to invoke a new " Initial Zero Calibration Reference". Any future deviation will be based on this new Zero.

Initial Zero

select P77

press "ENTER"

[P77 0] displayed

press "1"

press "ENTER"

[P77 1] displayed

press "ENTER"

[oo #####] displayed momentarily then,

[od 0.000] displayed

press "ENTER"

[oC #####] displayed, New Zero Count, zero calibration complete

Direct Zero Entry

Direct entry is intended for use when replacing software or hardware and it is not convenient to perform an initial zero at that time.

select P67

press "ENTER"

[P67 0] displayed

press "1"

press "ENTER"

[P67 1] displayed

press "ENTER"

[Pc 0.] displayed e.g. value '0' after a P99 reset

enter the recorded zero reference count of the previous zero (#####)

press "ENTER"

[oC #####] displayed, new zero count, entry complete.

Routine Span

To perform a routine span recalibration, ensure material flow is stopped and the prefeed is locked out. Attach the test weight to the flowmeter sensing plate. Refer to the associated flowmeter manual.

press "SPAN"

[SP #####] displayed, Current Span Count

press "ENTER"

[SP #####] displayed momentarily then,

[Sd #####] displayed, Span Deviation in %

press "ENTER"

[SC #####] displayed, New Span Count, span complete

If [SP E4] displayed, routine span attempt aborted, deviation from initial span calibration was greater than 12.5% of span.

An [E4] Display Message normally indicates a mechanical problem. Investigate the cause of the deviation and make the correction necessary. Retry the span calibration. If the deviation is determined to be acceptable, perhaps as the result of an intended mechanical change to the system, set P88 to 1 to invoke a new "Initial Span Calibration Reference". Further deviations will be based on this new Span.

Initial Span

select P88

press "ENTER"

[P88 0] displayed

press "1"

press "ENTER"

[P88 1] displayed

Press "ENTER"

[SP #####] displayed momentarily then,

[Sd 0.000] displayed

press "ENTER"

[SC #####] displayed, New Span Count, span calibration complete

Perform a material test if desired to verify the new calibration accuracy.

Direct Span Entry

Direct entry is intended for use when replacing software or hardware and it is not convenient to perform an initial span at that time.

select **P68**

press "**ENTER**"

[P68 0] displayed

press "**1**"

press "**ENTER**"

[P68 1] displayed

press "**ENTER**"

[Pc 0.] displayed e.g. value '0' after a P99 reset

enter the recorded span reference count of the previous span (**#####**)

press "**ENTER**"

[SC #####] displayed, new span count, entry complete

Self Initiated Auto Zero

Where frequent minor zero deviations are expected, the Compu-M self initiated auto zero feature may be utilized to perform an automatic zero calibration whenever the material flow ceases.

Connect a dry contact activated by a material prefeed control device such as a prefeed motor, material control gate, or valve to board B 1TB-1 and 2 of the Compu-M. The contact must be closed while the material prefeed is stopped.

While this contact is closed and after sensing no material flow through the flowmeter, the Compu-M will perform an auto zero. If the difference between the auto zero and the last operator initiated (routine) zero calibration is less than 2% of the design Rate (P1), the Compu-M will accept the auto zero results.

If the difference between the auto zero and the last routine zero is greater than 2% of the design Rate, the Compu-M will display [E9 - auto zero out of range] temporarily, reject the results of the auto zero attempt and then resume normal operation.

If the alarm relay is set for auto zero (P20 =3), the relay is de-energized and the display flashes. The alarm is in effect until an auto zero within range occurs, when a calibration is initiated, or when the rate exceeds 12% of design.

If the Compu-M displays [E9] after repeated auto zero attempts, the operator should perform a routine zero calibration. Future auto zero attempts will be referenced to this new zero calibration.

The Compu-M will continue to perform auto zero calibrations until the prefeed activated contact connected to TB1-1 and 2 is open. Any material totalized during a self initiated auto zero is added to the Compu-M total and the remote total. The analog mA output will respond to any material measured during a self initiated auto zero.

PARAMETERS

GENERAL

(F) indicates parameters' factory setting, where applicable

(V) indicates parameter can be viewed only.

PARAMETERS

P01 Mode Select

Defines the type of application. The Compu-M selects the appropriate Automatic Parameter Access (APA) software routine based on the value entered.

enter: 1 = belt scale (F)
2 = flowmeter

P02 Operation

Defines the type of transducing element utilized to provide the load signal input to the Compu-M.

enter: 1 = load cell (F)
2 = LVDT

P0 Rate Units

Defines the desired Rate Display engineering units of measure.

| | |
|---|-------------------|
| enter: 1 = MTPH, metric tons per hour (F) | 1MTPH = 1000 KG/H |
| 2 = KG/H, kilograms per hour | 1LTPH = 2240 LB/H |
| 3 = LTPH, long tons per hour | 1STPH = 2000 LB/H |
| 4 = STPH, short tons per hour | |
| 5 = LB/H, pounds per hour | |

Rate, Belt Speed and Belt Length (P1,P4,and P6) parameter values are not automatically converted if the previously entered Rate Units (P0) are changed. After altering the Rate Units, converted values must be entered manually for each of these parameters.

P1 Rate

Defines the rate of material flow which will produce the maximum Analog mA Output of 20 mA.

enter: Design Rate from Design Data Sheet (F = 0.000)

P2 Local Totalizer

Defines the amount of material to be registered by the Compu-M prior to initiating an internal totalizer update. The weight unit portion of the Rate Unit (P0) selected is assumed. (F = 1)

| | P2 Value | Total Display | # of Weight Units |
|--------|----------|---------------|---------------------|
| enter: | .001 | = ####.### | = thousandths |
| | .01 | = #####.## | = hundredths |
| | .1 | = #####.# | = tenths |
| | 1 | = ##### | = units (F = 1.000) |
| | 10 | = #####0 | = tens |
| | 100 | = #####00 | = hundreds |
| | 1000 | = #####000 | = thousands |

If the value selected is too low, the Compu-M will display [E2].
Enter a higher value.

P3 Remote Total

Defines the amount of material to be registered by the Compu-M prior to initiating a relay contact closure which may be utilized for remote totalization. The weight unit portion of the Rate Unit (P0) selected is assumed.

| | weight units | contact closures |
|--------|--------------|------------------|
| enter: | .001 | = 1 |
| | .01 | = 1 |
| | .1 | = 1 |
| | 1 | = 1 |
| | 10 | = 1 |
| | 100 | = 1 |
| | 1000 | = 1 |

If the value selected is too low, the Compu-M will display [E2].
Enter a higher value.

P4 Belt Speed (Belt Scale Applications Only)

Defines the Design Speed of the conveyor belt. After initial calibration, belt speed adjustments may be entered via P17 to avoid performing a new initial zero and span calibration.

The speed units are assumed to be:

metres/sec, if P0 = 1 (MTPH)
2 (KG/H)

feet/min, if P0 = 3 (LTPH)
4 (STPH)
5 (LB/H)

enter: Design Belt Speed from Design Data Sheet. (F = 0.000)

P5 Speed Constant (Belt Scale, Applications Only)

Defines the constant value the Compu-M must multiply to the Speed Sensor output frequency to establish the current belt speed.

**If a Speed Sensor is not utilized TB1-13,14 must be jumpered. The Compu-M automatically sets this value to 100. Do not alter this value, proceed to P6.
If a Speed Sensor is utilized, the jumper across TB1-13,14 must be removed.**

enter: Design Constant from Design Data Sheet. (F = 0.000)
OR

The resultant value of the following calculation.

$$\text{speed constant} = \frac{\text{Speed Sensor pulses per rev}^*}{\text{pulley circumference (m or ft)/rev}} = \text{pulses/m or pulses/ft}$$

* see Speed Sensor nameplate or consult Milltronics

P6 Belt Length (Belt Scale Applications Only)

Defines the length of the conveyor belt which passes over the belt scale. The belt length units are assumed to be:

metres, if P0 = 1 (MTPH)
2 (KG/H)

feet, if P0 = 3 (LTPH)
4 (STPH)
5 (LB/H)

enter: Belt Length from Design Data Sheet
or
Measured Belt Length (F = 0)

P7 Test Load/Rate

Test Load (Belt Scale Applications Only)

Defines the load to be registered by the Compu-M when the Test Chain or Test Weight is applied to the Belt Scale. Enter the value that is indicated on the Design Data sheet. Entering "0" or performing a Reset will return the Test Load to the 100% Design Load factory value.

The Test Load Units are assumed to be:

kg/m if P0 = 1 (MTPH)
2 (KG/H)

lb/ft if P0 = 3 (LTPH)
4 (STPH)
5 (LB/H)

enter: Test Load, as determined (F = 100% Design Load)

Test Rate (Flowmeter Applications Only)

Defines the desired Rate to be registered by the Compu-M when the Test Weight is applied to the flowmeter.

Refer to the associated flowmeter instruction manual for assistance with calibration procedures, and Test Weight or Test Rate calculations.

Enter the desired Test Rate as determined by the preceding calculation.

Entering "0" or performing a Reset will restore the Test Rate to the 100% Design Rate default value.

enter: Test Rate, as determined, (F = 100% Design Rate)

P8 Manual Span Adjust

Permits span calibration error correction, and automatically adjusts the current Test Load/Rate value.

This is accomplished by performing material tests and entering the span error (in percent). Refer to the appropriate Belt Scale Applications or Flowmeter Applications section for instructions.

enter: % Span Error, (as determined).

P9 Factoring

Establishes the Test Load/Rate (P7) value of the applied calibration reference, based on the current Compu-M Span calibration.

This feature may be used, to establish the Test Load/Rate (P7) value of a new or otherwise unknown Test Weight, based on the Compu-M Span calibration results obtained from the old Test Weight.

Before initiating the Factoring process:

- » Access the Test Load/Rate (P7) parameter and record the display value associated with the Test Weight(s) used to perform the current Span calibration.
- » Stop the material flow. (For belt scales, the belt must be running empty.)
- » With the Test Weight(s) removed, perform a Zero calibration.
- » Apply the new Test Weight(s).

During the Factoring process, the current Span count is displayed momentarily.

If [P9 E6] is displayed, refer to Programming/Display Messages.

When Factoring is complete, the Test Load/Rate (P7) value of the new Test Weight(s) is displayed. Copy the new P7 value to the Programming Chart.

Ensure the appropriate Test Load/Rate (P7) value is entered, before performing subsequent Span calibrations with the old or new Test Weight(s).

enter : 0 = Factoring not required (F)
1 = initiate Factoring procedure

P10 Total Dropout %

Defines the limit, in percentage of the design rate, below which material rates will not be totalized. A value of zero will permit the Compu-M to count up or down. Relay contact closures for remote totalization will not continue until the Compu-M totalized value regains the amount by which it counted down.

enter: limit in percentage of design rate (F = 3.000)

P11 Damping

Defines the level of damping to be applied to the Compu-M local display values and the Analog mA Output. The range of possible values is 1 to 9999 with values of 1 to 50 being typical operating values. The greater the damping value, the slower the Compu-M displays and analog output will respond to a change in Rate. Refer to P18 for additional Analog mA Output damping.

enter: Damping, as determined, (F = 1.000)

P12 Rate Output

Defines the span of the Analog mA Output which corresponds proportionally to the material rate registered by the Compu-M.

enter: 1 = 4 - 20 mA (F)
2 = 0 - 20 mA

P13 Minimum Output Adjust

Permits limited adjustment of the Compu-M minimum Rate Output (as selected by P12). This adjustment may be used to match the minimum input required by the attached external device. e.g. mA meter.

The following display values are not crucial but represent typical Compu-M displays. If P12 = 1, (4 mA min. output) the Compu-M will display a value \cong 600. If P12 = 2, (0 mA min. output) the Compu-M will display a value \cong 0.

To increase the output press "4". To decrease the output press "8". The Compu-M display value will increase or decrease in relation to the change in the analog mA output.

e.g. P12 = 1
select P13
press "ENTER"
P13 [666] displayed
external meter reads 3.8 mA
press "4" to increase the displayed value until 4.0 mA is displayed on the external meter.
press "ENTER"

P14 Maximum Output Adjust

Permits limited adjustment of the Compu-M maximum Analog mA Output, 20 mA. This adjustment may be used to match the maximum input required by the attached external device. e.g. mA meter.

When this parameter is accessed the Compu-M will display a value $\cong 3300$, the mA output will be 20 mA. To increase the output press "4". To decrease the output press "8". The Compu-M display will increase or decrease in relation to the change in the analog mA output.

e.g. select P14
press "ENTER"
P14 [3325] displayed
external meter displays 20.2 mA
press "8" to decrease the displayed value until 20.0 mA is displayed on the external meter.
press "ENTER"

P15 Diagnostic Meter (V)

Activates the Compu-M input signal measurement functions. To advance to the next function press "ENTER".

[P15U ###] displayed, range = 0 to 3.98 Volts DC

The value displayed is proportional to the input level supplied by the load cell(s) or the LVDT.

[F #####] displayed, range = 0 to 131,072 counts.

High resolution reference value display, proportional to load cell or LVDT input signal levels.

* [P15A #####] displayed, Load Cell A input in mV (P02=1).

* [P15b #####] displayed, Load Cell B input in mV (P02=1).

select P15

[P15] displayed.

press "ENTER"

[P15U ###] displayed.

press "ENTER"

[F #####] displayed.

press "ENTER"

* [P15A #####] displayed.

press "ENTER"

* [P15b #####] displayed.

* Load Cell applications only, (P02=1)

P16 Remote Totalizer Relay Closure

Defines the on-time duration of the remote totalizer relay contact closure. The on/off cycle time for this relay is automatically determined by the operator entered values of Rate (P1) and Remote Total (P3). To determine the on-time duration required, refer to the specifications stated by the manufacturer of the remote totalizer (or other device) to be utilized. If the combination of the values entered in P1, P3, and P16 exceed the operating limits of the system the Compu-M will display, [E2], indicating the value of P3 should be increased.

- | | |
|--------------|--------------|
| 1 = 32 msec | 6 = 192 msec |
| 2 = 64 msec | 7 = 224 msec |
| 3 = 96 msec | 8 = 256 msec |
| 4 = 128 msec | 9 = 288 msec |
| 5 = 160 msec | |

enter: desired value

P17 Speed Constant Adjust (Belt Scale Applications Only)

Prior to the initial entry of a value into this parameter, the current dynamic belt speed is displayed. If the speed displayed by the Compu-M is not equal to the actual belt speed, enter the actual belt speed. The use of this parameter does not require a system recalibration.

Where a Speed Sensor is not used, (TB1-13,14 jumpered), the entry of the new or measured belt speed value causes the Compu-M to automatically alter the Belt Speed (P4) value.

Where a Speed Sensor is used, (TB1-14 open), the entry of the new or measured belt speed value causes the Compu-M to automatically alter the Speed Constant (P5) value.

enter: new or measured speed

P18 Rate Output Damping

Defines the level of damping to be applied to the Analog mA output. The use of this parameter permits variations in stabilization between the Compu-M local displays, and the Rate Output. Analog mA Output damping equals Display damping if P18 = 0. The range of possible values is 0 - 9999, dependent upon the value entered in P11.

enter: Rate Output Damping, desired (F = 0)

P20 Alarm

This parameter sets the alarm function: rate, belt speed or auto zero out of range.

The setpoint units for rate alarm are % of design rate, P1. The setpoint units for belt speed are % of design belt speed, P4. The hysteresis for rate alarm and speed alarm is 2% of the design rate (P1) or belt speed (P4), respectively.

enter: 0 = off, relay de-energized

1 = rate alarm, setpoints

press "ENTER"

[P20L 20] e.g. low alarm, factory setting = 20%

press "ENTER"

[P20H 100] e.g. high alarm, factory setting = 100%

press "ENTER"

[P0 1] exit

2 = fixed rate alarm, setpoints: low = 20%
high = 100%

3 = auto zero out of range - E9 message

4 = speed alarm setpoints (belt scale applications only)

press "ENTER"

[P20L 20] e.g. low alarm, factory setting = 20%

press "ENTER"

[P20H 100] e.g. high alarm, factory setting = 100%

press "ENTER"

[P0 1] exit

P21 Auto Scroll Display

Allows automatic scrolling of the rate and total displays.

enter: 0 = off

1 = alternating

To exit into Run, use 'RUN' key.

Press 'ALT DISP' to stop auto scroll and resume manual scroll (P21 automatically resets to '0').

P24 Linearizer (flowmeter mode only)

Linearizes flowrate to compensate for material flows exhibiting non-linear characteristics.

enter 0 = disabled
1 = enabled

Press "**ENTER**" to scroll through the linearizer compensation points L1, L2, L3 and the associated compensation values L1c, L2c, L3c.

Enter the Lx values in the rate units, P0, and the compensation values in the calculated percentages.

Refer to Applications\Solids Flowmeters\Linearization.

P25 Zero Limit

This parameter sets the zero calibration deviation limit. If the deviation exceeds the selected limit, the calibration will be aborted and an E3 message will be displayed.

enter: 0 = 12.5% of initial span from the initial zero (F)
1 = 2% of initial span from the last operator initiated zero

P30 Calibration Duration

For Belt Scale applications; if P30 = 1 the automatic belt length detection feature is utilized requiring up to 4 belt revolutions, otherwise this parameter defines the number of belt revolutions the Compu-M will utilize to perform a zero or span calibration.

For Flowmeter applications; defines the number of time periods the Compu-M will utilize to perform a zero or span calibration (1 time period \approx 10 seconds).

A lower value may be selected to reduce calibration time. A higher value may be utilized to improve the calibration accuracy. Parameter value range = 1 to 99

enter: Calibration Duration, desired (F = 1)

P50 Zero Register (V)

Displays the number of Zero Calibrations that have been performed since the last Master Reset, (P99 = 9). This register is not affected by a partial reset, (P99 = 1).

select P50

press "**ENTER**" (F = 0)

P67 Direct Zero Entry

Allows direct access to the zero reference count.

Direct entry is intended for use when replacing software or hardware and it is not convenient to perform an initial zero at that time.

enter : **0** = disabled
1 = enabled

press "**ENTER**"
[Pc #####] displayed, previous count (display '0' if no previous count)
press "**12345**" e.g. count value 12345
press "**ENTER**"
[oC 12345] e.g. new count value

P68 Direct Span Entry

Allows direct access to the span reference count.

Direct entry is intended for use when replacing software or hardware and it is not convenient to perform a span at that time to establish a proper initial span.

enter: **0** = disabled
1 = enabled

press "**ENTER**"
[Pc #####] displayed, previous count (display '0' if no previous count)
press "**67890**" e.g. count value 67890
press "**ENTER**"
[SC 67890] e.g. new count value

P77 Initial Zero

Activates a Zero calibration which the Compu-M will utilize as a reference to which subsequent routine Zero calibrations will be compared.

This parameter is generally utilized in response to a Display Message **[E3]**, when an accountable but mechanically non recoverable zero deviation, of greater than 12.5% of span, has occurred.

Refer to the appropriate recalibration section of this manual.

enter: "**1**", Initial Zero (F = 0)

P88 Initial Span

Activates a Span calibration which the Compu-M will utilize as a reference to which subsequent routine span calibrations will be compared.

This parameter is generally utilized in response to a Display Message [E4], when an accountable but mechanically non-recoverable zero calibration deviation, greater than 12.5% of span has occurred.

Refer to the appropriate recalibration section of this manual.

enter: "1", Initial Span (F = 0)

P91 Calculator Input 1 (Belt Scale Applications Only)

Displays the count reference value of the summed inputs from load cell A and B when Compu-M board B switch SW1 is closed. Placing the test weight on load cell B side of the belt scale and entering the displayed value automatically advances the display to the next sequential parameter.

P92 Calculator Input 2 (Belt Scale Applications Only)

Displays the count reference value of the load cell B input when Compu-M board B switch SW1 is open. Without disturbing the test weight position (P-91), entering the value displayed automatically advances the display to the next sequential parameter.

P93 Calculator Input 3 (Belt Scale Applications Only)

Displays the count reference value of the load cell B input when Compu-M board B switch SW1 is open. Placing the test weight on the load cell A side of the belt scale and entering the value displayed automatically advances the display to the next sequential parameter.

P94 Calculator Input 4 (Belt Scale Applications Only)

Displays the count reference value of the summed inputs from load cell A and B when Compu-M board B switch SW1 is closed. Without disturbing the test weight position (P93), entering the value displayed automatically advances the display to the next sequential parameter.

P95 Load Cell Balance (Belt Scale Applications Only)

Utilizes the display values entered sequentially from P91 through P94 to calculate and display a value representative of the load cell input signal balance. Without disturbing the test weight position (P93), the operator adjusts the Compu-M board B "A BAL" potentiometer while observing the effect on the displayed value. The load cell signal inputs are sufficiently balanced when the value displayed equals 0 ± 5 counts. Pressing "ENTER" returns the display to P91, to exit the loop press any other command key.

Should the "A BAL" potentiometer of a calibrated Compu-M require adjustment, an initial zero and span calibration must be performed. A material test may be required to verify system accuracy.

P99 Reset

Initiates a Compu-M memory reset. This feature clears undesired data from the Compu-M memory and restores parameter values to the original factory settings. The implementation of a Reset requires total reprogramming and calibration.

select P99

press "ENTER"

[P99 0] displayed

press "9",

[P99 9] displayed

press "ENTER" (diagnostic messages temporarily displayed)

[P] displayed, Reset complete.



MAINTENANCE

The Compu-M requires no maintenance.

The enclosure may be cleaned using a vacuum cleaner and a clean, dry paint brush.

It is also a good idea to check the associated load sensing device, according to its instruction manual.



PROGRAMMING CHART

| | | |
|------------------------------|---------|---|
| P01 MODE: | [] | 1 = belt scale, 2 = flowmeter |
| P02 OPERATION: | [] | 1 = load cell, 2 = LVDT |
| P0 UNITS: | [] | rate display, 1= MTPH, 2 = KG/H, 3 = LTPH, 4 = STPH, 5 = LB/H |
| P1 DESIGN RATE: | [] | from design data sheet |
| P2 LOCAL TOTAL: | [] | registration multiplier, refer to parameters |
| P3 REMOTE TOTAL: | [] | registration multiplier, refer to parameters |
| * P4 BELT SPEED: | [] | from design data sheet m/sec or ft/min. |
| * P5 SPEED CONSTANT: | [] | from design data sheet |
| * P6 BELT LENGTH: | [] | from design data sheet or as measured, m or ft |
| P7 TEST LOAD/RATE: | [] | KG/M or LB/FT (belt scales) MTPH,KG/H,LTPH,STPH or LB/H (flowmeters) |
| ZERO CALIBRATION | [] | observed Initial zero referencecount |
| SPAN CALIBRATION | [] | observed Initial span reference count |
| P8 MANUAL SPAN ADJUST: | [] | material test % span error |
| P9 FACTORING: | [] | test weight correction 0 = no, 1 = yes |
| P10 TOTAL DROPOUT: | [] | totalizer cutoff point % |
| P11 DAMPING: | [] | local display and rate output, from 1 to 9999 |
| P12 RATE OUTPUT: | [] | 1 = 4-20 mA, 2 = 0-20 mA |
| P16 TOTALIZER RELAY: | [] | on-time closure duration, from 1 to 9 |
| * P17 SPEED CONSTANT ADJUST: | [] | actual belt speed m/sec or ft/min |
| P18 RATE OUTPUT DAMPING: | [] | if other than P11 value, from 0 to 9999 |
| P20 ALARM RELAY: | [] | 0 = off, 1 = rate set point: Low [] High [] 2 = fixed rate 3 = auto zero * 4 = speed set points: Low [] High [] |
| P21 AUTO SCROLL DISPLAY: | [] | 0 = off, 1 = alternating |
| ▲P24 LINEARIZER: | [] | 0 = disabled 1 = enabled L1 [] L2 [] L3 [] L1c [] L2c [] L3c [] |
| P25 ZERO LIMIT: | [] | 0 = 12.5%, 1= 2% |
| P30 CALIBRATION DURATION: | [] | utilized for zero or span calibrations, from 1 to 99 |
| P67 DIRECT ZERO ENTRY: | [] | 0 = disabled 1 = enabled |
| P68 DIRECT SPAN ENTRY: | [] | 0 = disabled 1 = enabled |

* parameter applicable to belt scale applications only, P01 = 1
▲ parameter applicable to flowmeter applications only, P01 = 2

