

LaBOUNTY SALES MANUAL MOBILE SHEARS

MSD SHEAR DIMENSIONS AND WEIGHTS STANDARD AND (METRIC)

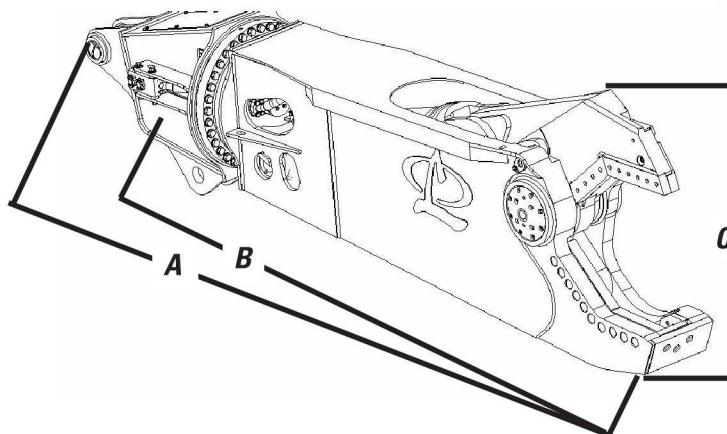

**MSD SABER SERIES ROTATING SHEAR
SECOND MEMBER MOUNT SHOWN**

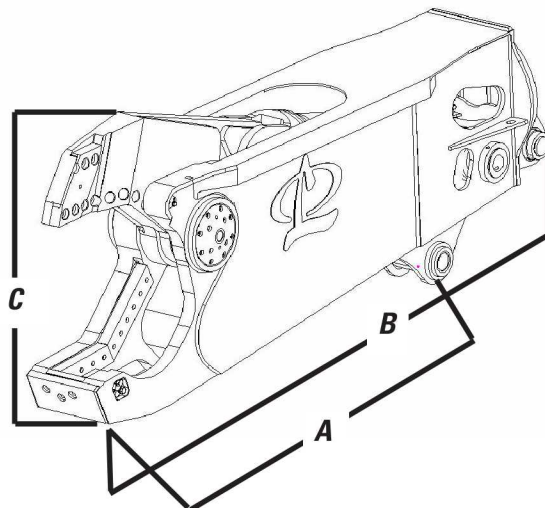

**MSD SABER SERIES NON-ROTATING SHEAR
SECOND MEMBER MOUNT SHOWN**

MSD SABER AND SABER LUBE SPECIFICATIONS

MODEL	EXCAVATOR WEIGHT		EXCAVATOR WEIGHT		ATTACHMENT WEIGHT		JAW OPENING		JAW DEPTH		REACH (2ND MEMBER)	
	2ND MEMBER	3RD MEMBER	2ND MEMBER	3RD MEMBER	LBS.	KG.	IN.	MM	FT.	MM	FT.	M
	LBS.	M TONS	LBS.	M TONS								
MSD 800	15,000	7	20,000	10	2,735	1,021	15	381	17	432	7'3"	1.7
MSD 800R	18,000	9	26,000	12	2,250	1,241	15	381	17	432	7'3"	2.2
MSD 1000	20,000	9	35,000	16	4,200	1,910	19	482	20	508	5'11"	1.8
MSD 1000R	23,000	10	40,000	18	4,400	2,000	19	482	20	508	8'6"	2.5
MSD 1500	27,000	12	55,000	25	6,600	3,000	22	559	25	635	6'9"	2.1
MSD 1500R	40,000	18	66,000	30	7,000	3,180	22	559	25	635	9'3"	2.8
MSD 2000	42,000	19	70,000	32	8,850	4,020	28	711	29	737	8'3"	2.5
MSD 2000R	50,000	23	90,000	41	10,200	4,636	28	711	29	737	11'0"	3.4
MSD 2000-SL	42,000	19	70,000	32	9,050	4,110	28	711	29	737	8'3"	2.5
MSD 2000R-SL	50,000	23	90,000	41	10,400	4,727	28	711	29	737	11'8"	3.5
MSD 2250	44,000	20	88,000	40	10,500	4,800	30	762	30	762	8'0"	2.4
MSD 2250R	55,000	25	110,000	50	12,500	5,670	30	762	30	762	11'9"	3.6
MSD 2500	50,000	23	90,000	41	12,000	5,450	32	813	34	864	8'9"	2.7
MSD 2500R	70,000	32	110,000	50	14,600	6,640	32	813	34	864	12'6"	3.8
MSD 2500-SL	50,000	23	90,000	41	12,000	5,450	32	813	34	864	8'9"	2.7
MSD 2500R-SL	70,000	32	110,000	50	14,800	6,730	32	813	34	864	12'6"	3.8
MSD 3000	70,000	32	144,000	65	13,300	6,045	35	889	38	965	9'10"	3.0
MSD 3000R	95,000	43	160,000	73	17,000	7,730	35	889	38	965	14'1"	4.3
MSD 3000-SL	70,000	32	144,000	65	13,500	6,140	35	889	38	965	9'10"	3.0
MSD 3000R-SL	95,000	43	160,000	73	17,200	7,820	35	889	38	965	14'1"	4.3

SPECIFICATIONS CONTINUED ON NEXT PAGE

NOTICE

Please note that the above specifications marked can vary by approximately 10 - 15 percent, depending upon the bracket configuration required/requested. These dimensions are for calculating shipping costs only. If accurate dimensions are required, please contact LaBounty.

LaBOUNTY SALES MANUAL

MOBILE SHEARS

MSD SABER AND SABER LUBE SPECIFICATIONS

MODEL	EXCAVATOR WEIGHT 2ND MEMBER		EXCAVATOR WEIGHT 3RD MEMBER		ATTACHMENT WEIGHT		JAW OPENING		JAW DEPTH		REACH (2ND MEMBER)	
	LBS.	M TONS	LBS.	M TONS	LBS.	KG.	IN.	MM	FT.	MM	FT.	M
MSD 4000	80,000	36	150,000	68	16,600	7,500	40	1000	44	1,100	12'0"	3.4
MSD 4000R	100,000	45	170,000	77	19,000	8,600	40	1000	44	1,100	14'11"	4.5
MSD 4500	90,000	41	160,000	73	17,900	8,140	38.5	978	43	1,092	10'8"	3.3
MSD 4500R	110,000	50	185,000	84	21,000	9,545	38.5	978	43	1,092	14'2"	4.3
MSD 4500-SL	90,000	41	160,000	73	18,100	8,230	38.5	978	43	1,092	10'8"	3.3
MSD 4500R-SL	110,000	50	185,000	84	21,200	9,640	38.5	978	43	1,092	14'2"	4.3
MSD 7500	135,000	61	consult factory		25,500	11,590	43	1092	45	1,143	11'10"	3.6
MSD 7500R	160,000	73	275,000	125	30,000	13,640	43	1092	45	1,143	15'7"	4.7
MSD 7500-SL	135,000	61	consult factory		25,700	11,680	43	1092	45	1,143	11'10"	3.6
MSD 7500R-SL	160,000	73	275,000	125	30,200	13,730	43	1092	45	1,143	15'7"	4.7
MSD 9500	175,000	80	consult factory		37,300	16,950	48	1219	52	1,321	15'4"	4.6
MSD 9500R	275,000	125	consult factory		43,300	19,680	48	1219	52	1,321	18'4"	5.6
MSD 9500-SL	175,000	80	consult factory		37,500	17,050	48	1219	52	1,321	15'4"	4.6
MSD 9500R-SL	275,000	125	consult factory		44,500	20,230	48	1219	52	1,321	18'4"	5.6

Note: Actual weights will vary, depending up options chosen, excavator bracket requirements, etc. All applications must be approved by Stanley LaBounty Applications Engineering.

1

Excavator weight recommendation is based on standard excavator weights and boom and/or arm lengths. All applications must be approved by Stanley LaBounty prior to sale.

2

Attachment weights can vary +/-5%, depending on mounting bracket configuration. The bolt-on cylinder lug option will add about 500-600 lbs to the above weights.

3

Reach figures for typical distance from boom/arm tip of base machine to tip of shear. Actual reach may vary. When reach is critical, call Stanley LaBounty for precise figures.

MSD SABER SERIES MOBILE SHEARS KEY FEATURES

LaBounty Built Reversed Cylinder/Reduced Shroud Height means better visibility and the ability to withstand extreme environments. The forged, solid cylinder rod is fully protected inside the back of the stick. The cylinder barrel is made from high strength steel and is heavy walled. All Saber Series models are designed to withstand up to 5500psi operating pressures.

180° Reversible Bolt-on Saber Tip can be changed out in less than 20 minutes. The result is a significant reduction in maintenance and down time. Also, because it's reversible, parts investment is maximized.

Dual Glide Slide Puck Sytem, a LaBounty original, makes use of opposing and offset guide mechanisms for the upper jaw on both sides of the shear, which increases upper jaw life and blade. The system also reduces jamming and increases productivity (models 2000 and up).

Patented, Spool Type Speed Valve for fastest cycle times. The proprietary spool type speed valve used by LaBounty has proved to be the most reliable and durable valve on the market—much more so than cartridge valve types.